

Plastic model kit containing 360 parts.

Wing span: 648mm Length: 443mm

1/48  
SCALE



01F005

# Avro Lancaster B Mk.I

## History of the Avro Lancaster

**F**rom failure to success. The four-engine Avro type 683 Lancaster was developed from the disappointing twin-engine Manchester, which suffered from engine fires caused by its unreliable Rolls Royce Vulture engine-installation.

However, the basic Manchester airframe was of sound design. A logical solution was to increase the wingspan and replace the two Vultures with four Merlin engines. The engine-installation originally developed by Rolls-Royce for the Beaufighter II, was quickly adapted and fitted in graceful underslung nacelles. The prototype BT308 made its first flight on January 9th, 1941 and it soon proved to be an excellent aircraft with good handling and high load capability. Initially designated Manchester III, it was soon renamed Lancaster. The general outline of the Lancaster remained the same throughout production, apart from the MK II which used Bristol Hercules radial engines, in case a shortage of the Merlin should arise. The Mk I and III were similar, differing only in the type of

Merlin engine fitted. In the case of the Mk III, the Packard built Merlin 28 was utilised. The Lancaster began to equip bomber squadrons in early 1942, where it quickly became the backbone of RAF Bomber Command.

The type was used in many famous raids, such as on the M.A.N. factory in Augsburg, the spectacular Dambusters Raid on the Ruhr Valley dams, and sinking the "Tirpitz" to name but a few. It became famous for its use in high accuracy bombing operations by 617 squadron. Its 33-foot-long bomb bay enabled it to carry high loads as well as the spinning "Upkeep" mine used to break the Ruhr dams. Specially adapted aircraft could carry the massive 12.000 lb "Tallboy" and 22.000 lb "Grand Slam" earthquake bombs.

At the end of the war it was also used for food dropping sorties for the starving Dutch population and transporting the many prisoners of war back home from Germany. Postwar Lancasters were used for testing jet engines and in-flight refueling system. As a bomber it was gradually replaced, but it found a useful role in Coastal Command until the last one was withdrawn in October 1956. The RCAF and French L'Aéronavale, however, continued to use the Lancaster until the mid-sixties. A total of 7,377 Lancasters were built in the UK and Canada.



BE CAREFUL



REMOVE



GLUE TOGETHER



PLEASE WAIT FOR A FEW MINUTES UNTIL DRY



MAKE 2 PIECES



DRILL HOLE



DO NOT GLUE



INSTANT GLUE FOR METAL



BEND



FILL HOLE



SEQUENCE OF WORK



OPTIONAL



USED COLOUR



APPLY DECAL



MARKING OPTION

### CAUTION

When using both glue and paint, do not use these near an open flame, due to the flammable properties of these items.

The symbols provided, such as 'X', refer to the basic colours of parts, although a more comprehensive list is supplied for your use for Tamiya, Mr Hobby and AK-Interactive codes.

When removing parts from sprues, take extreme care. Consider correct tools such as Xuron Sprue Cutters

Please check the symbology on the left and familiarise yourself before building this model kit.

In cooperation with:



www.ak-interactive.com



Large Scale Modeller

www.largescalemodeller.com



HK MODELS 01F005

PAGE 01

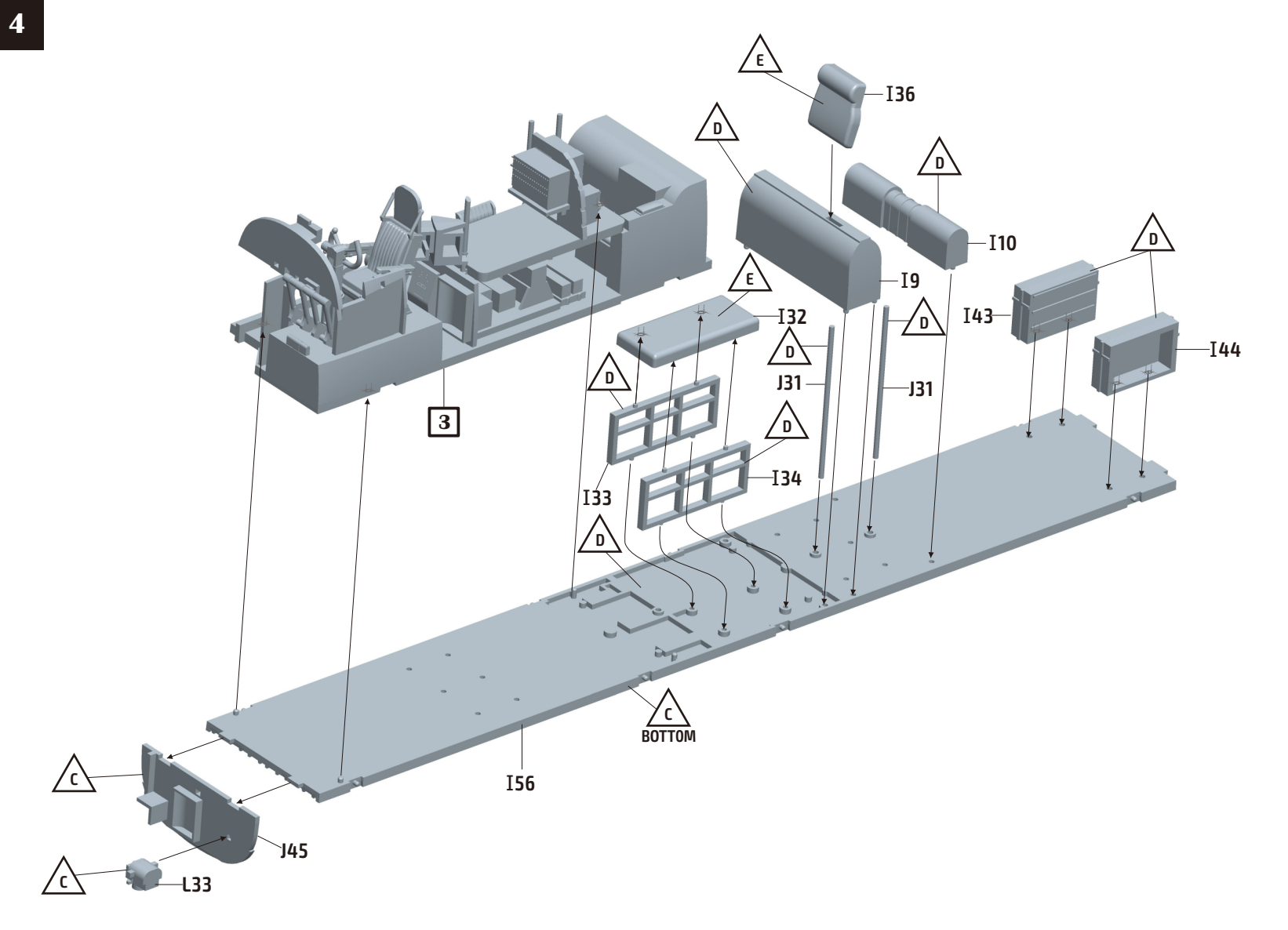
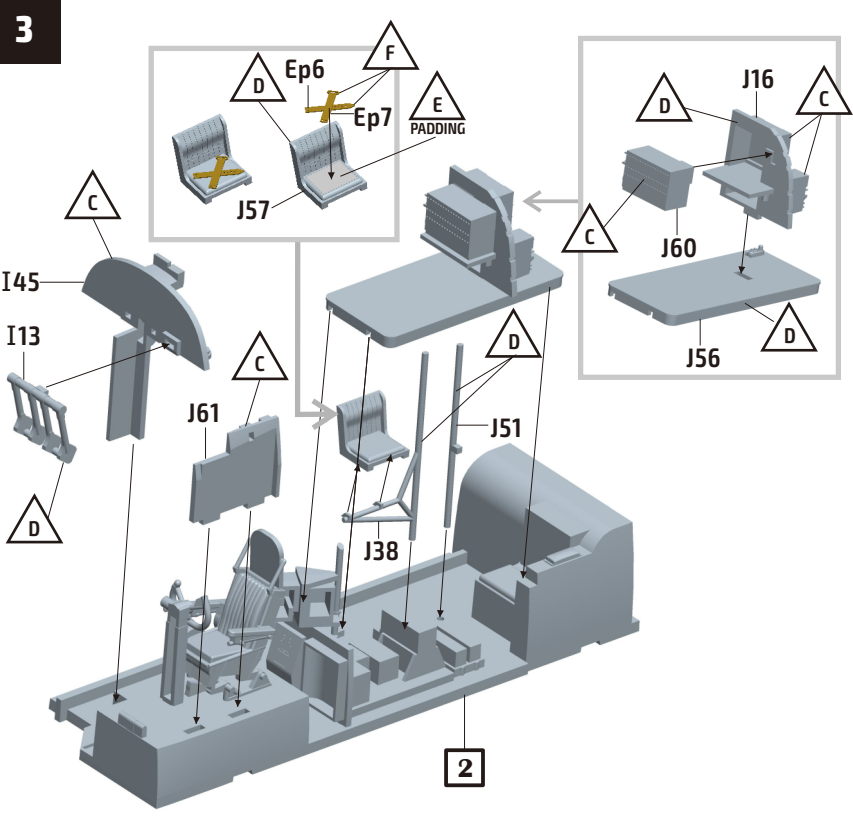
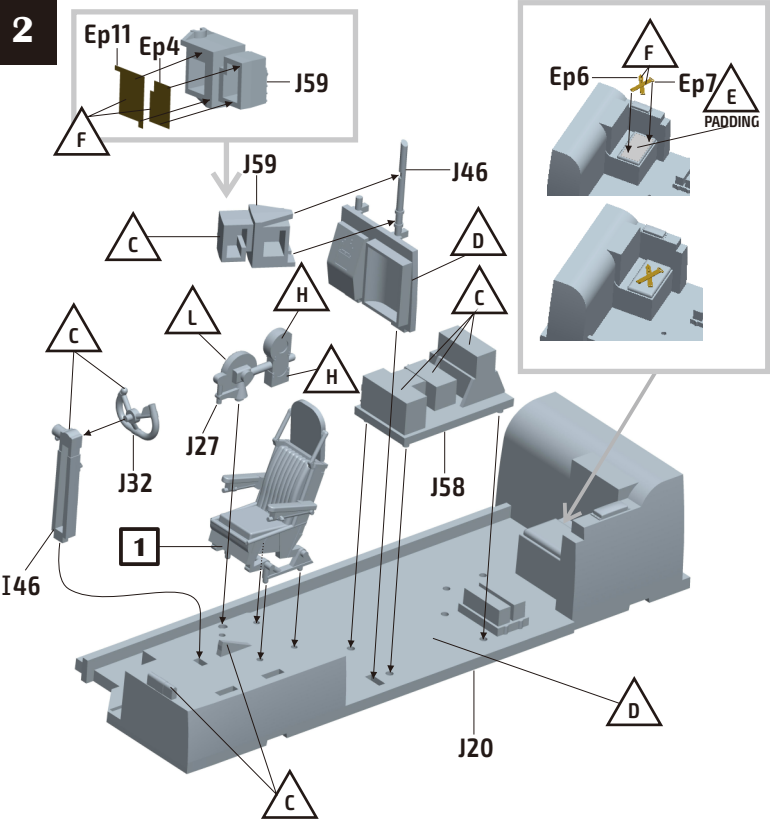
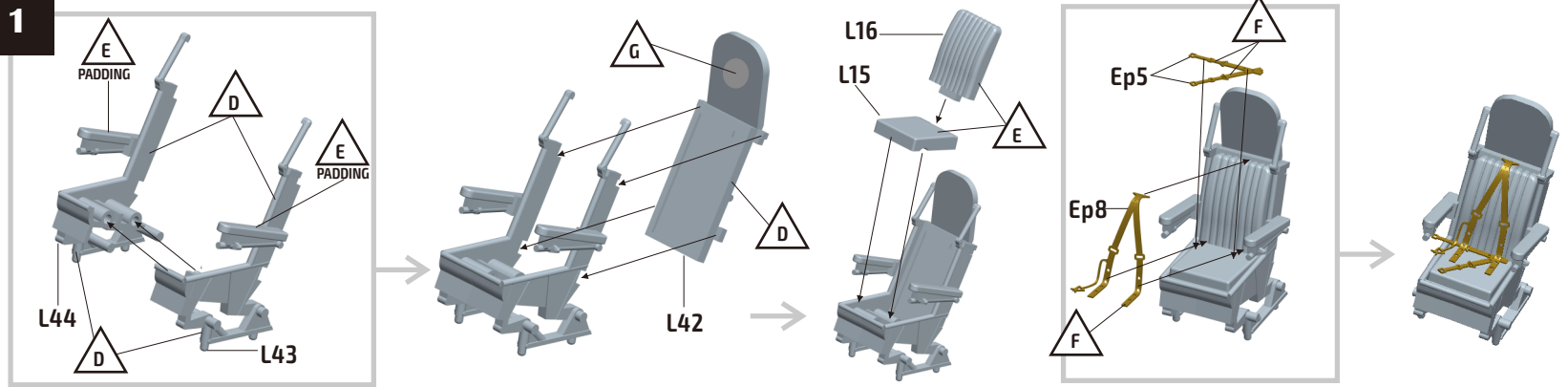

5

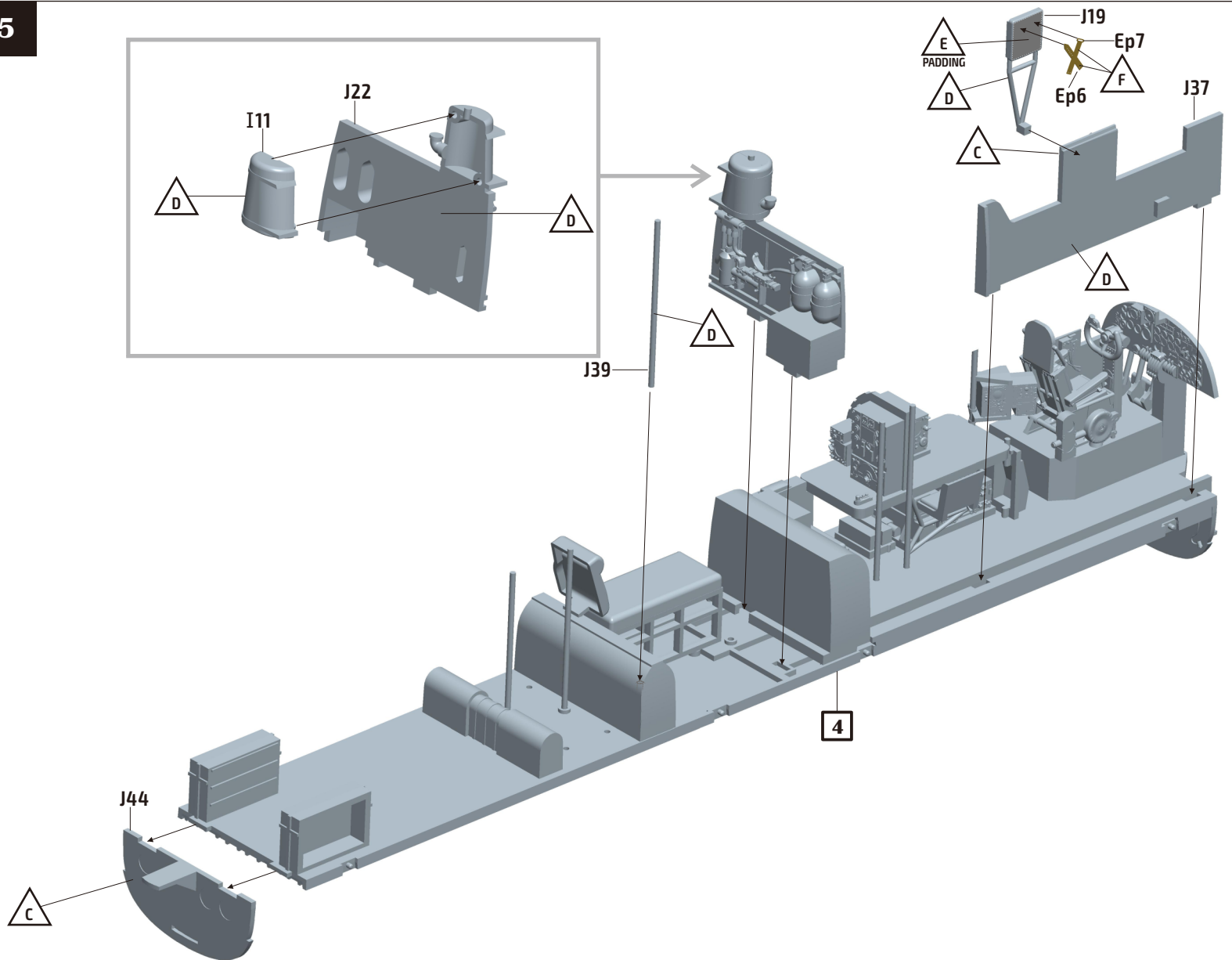

6

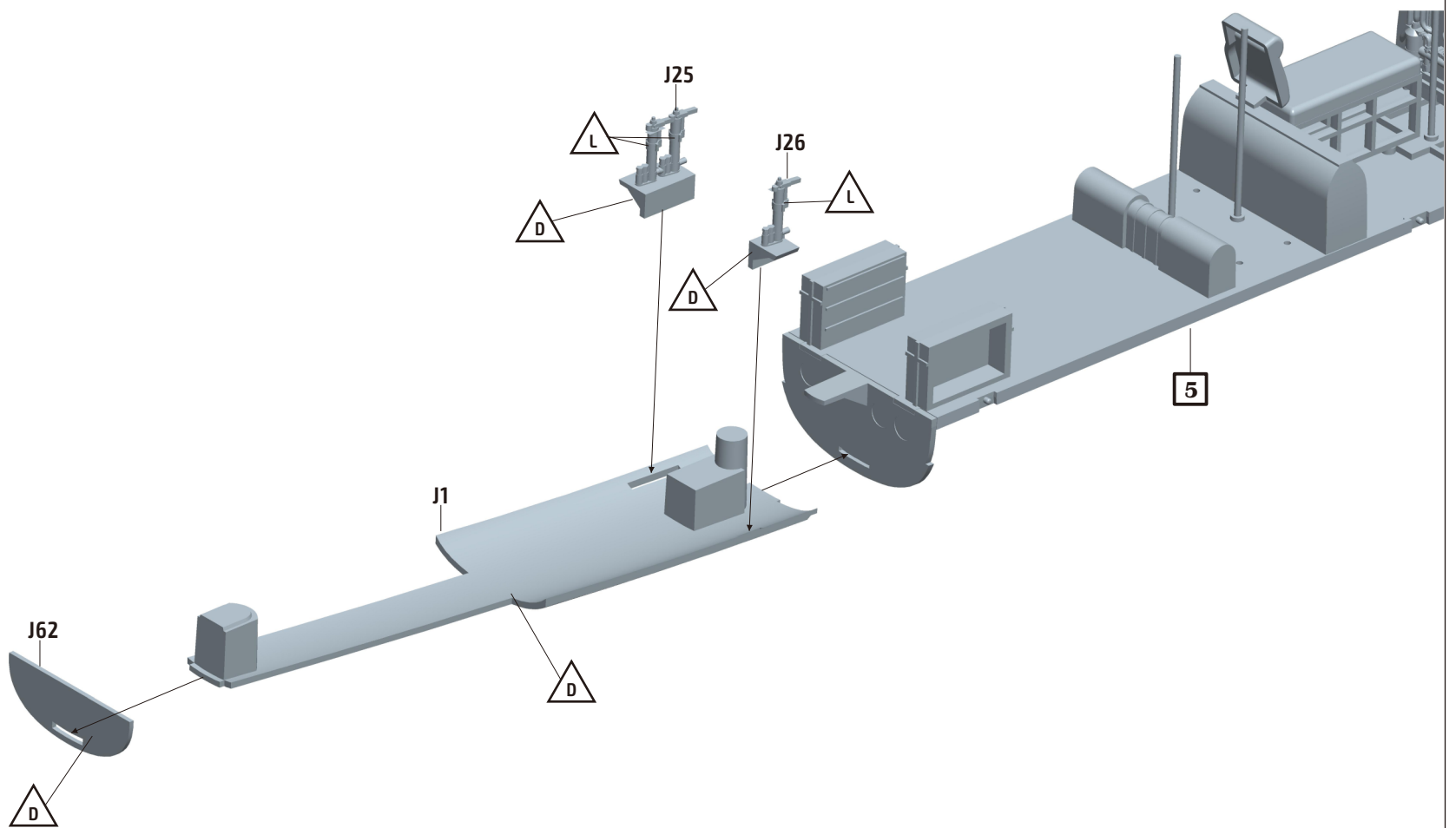

7

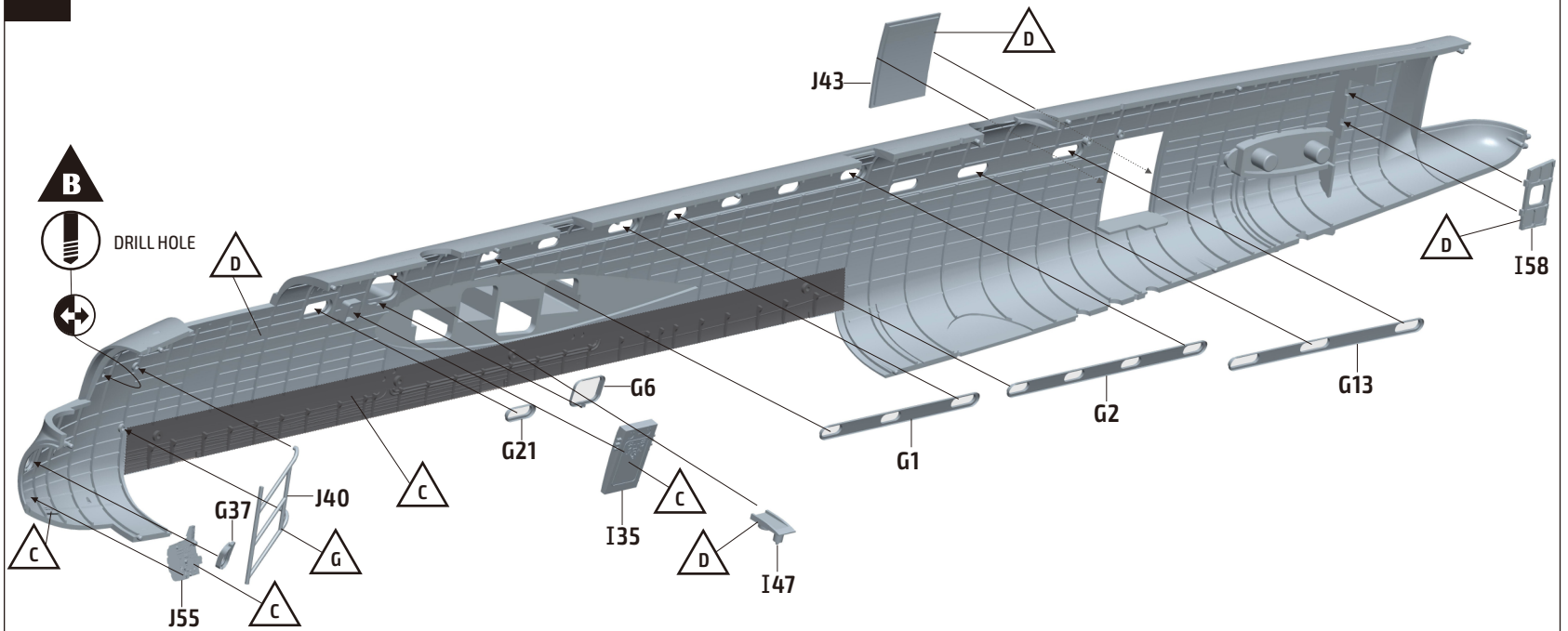

8

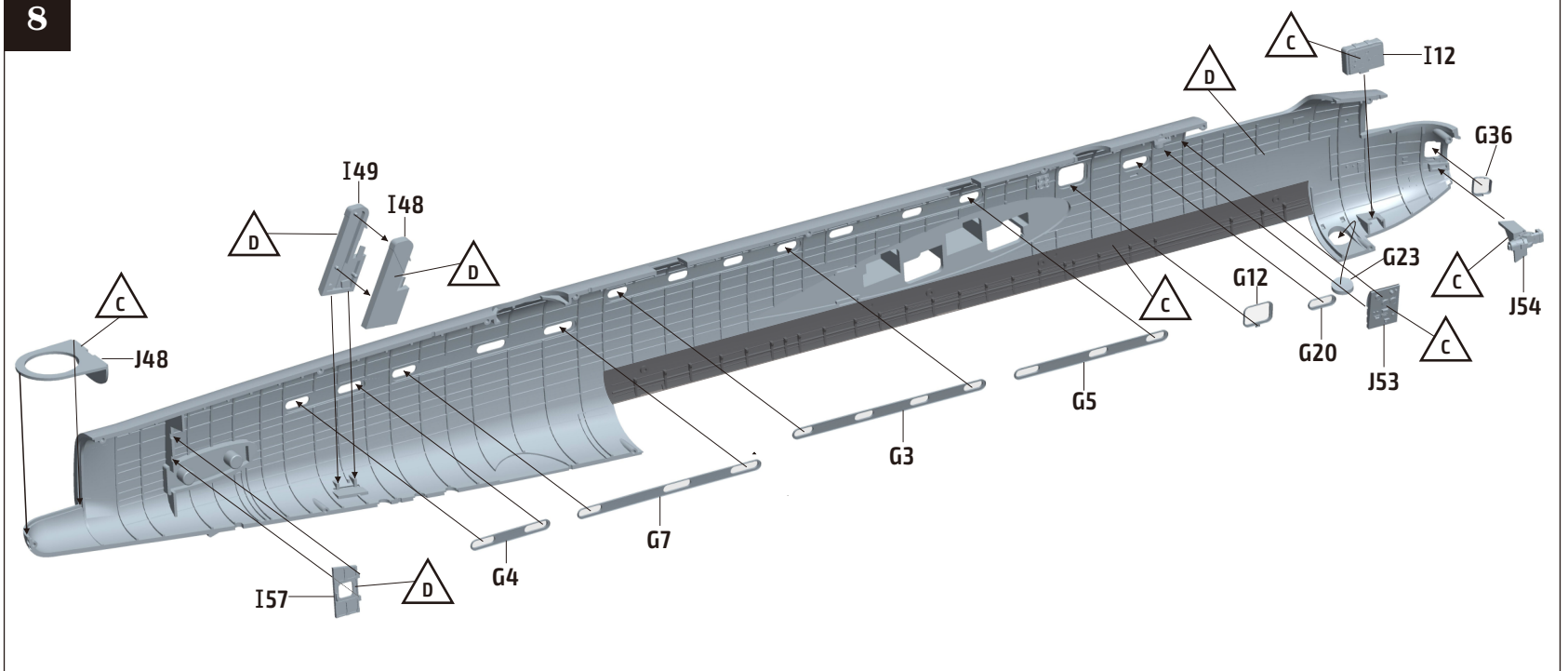

9

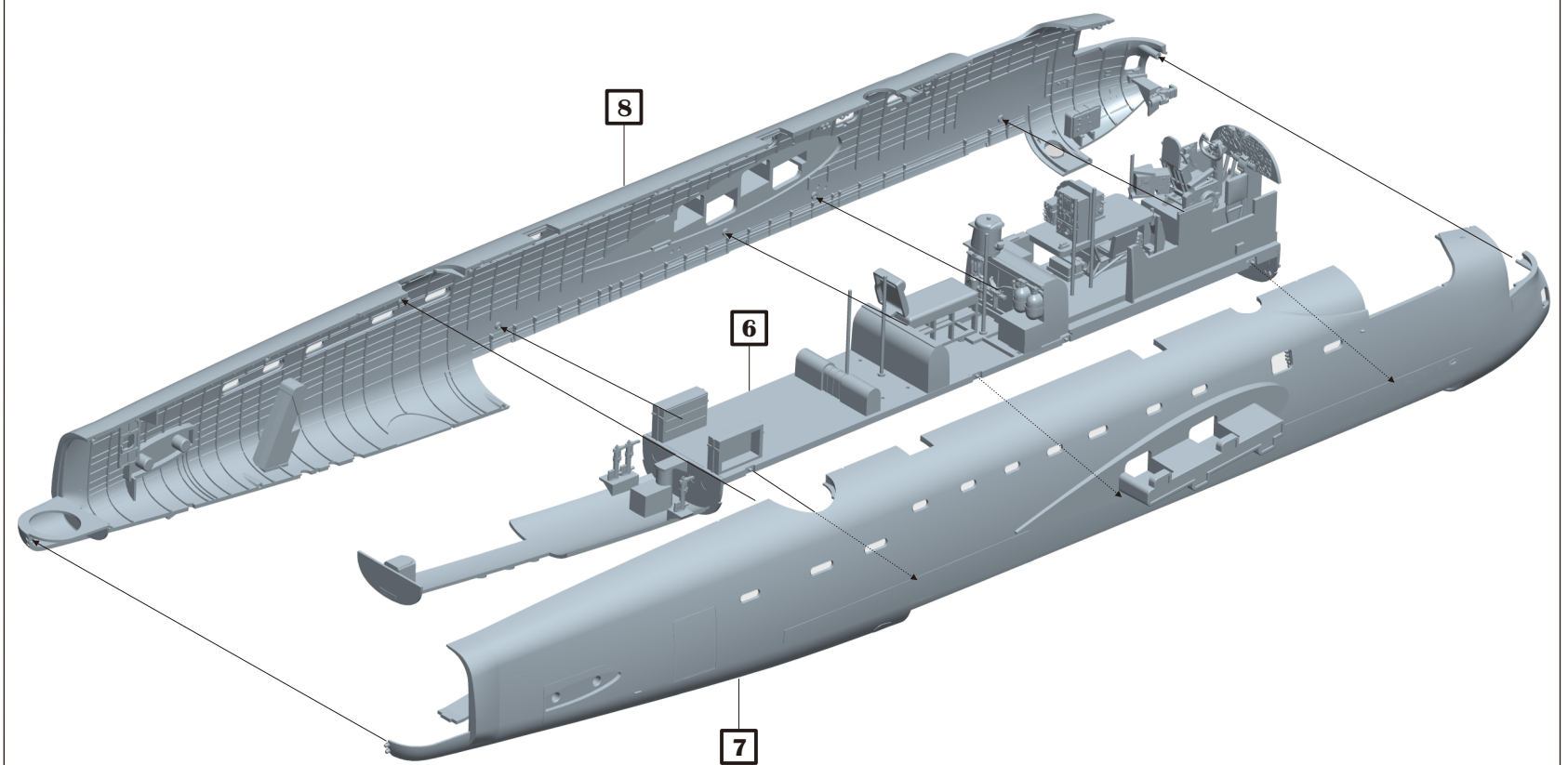

**10**

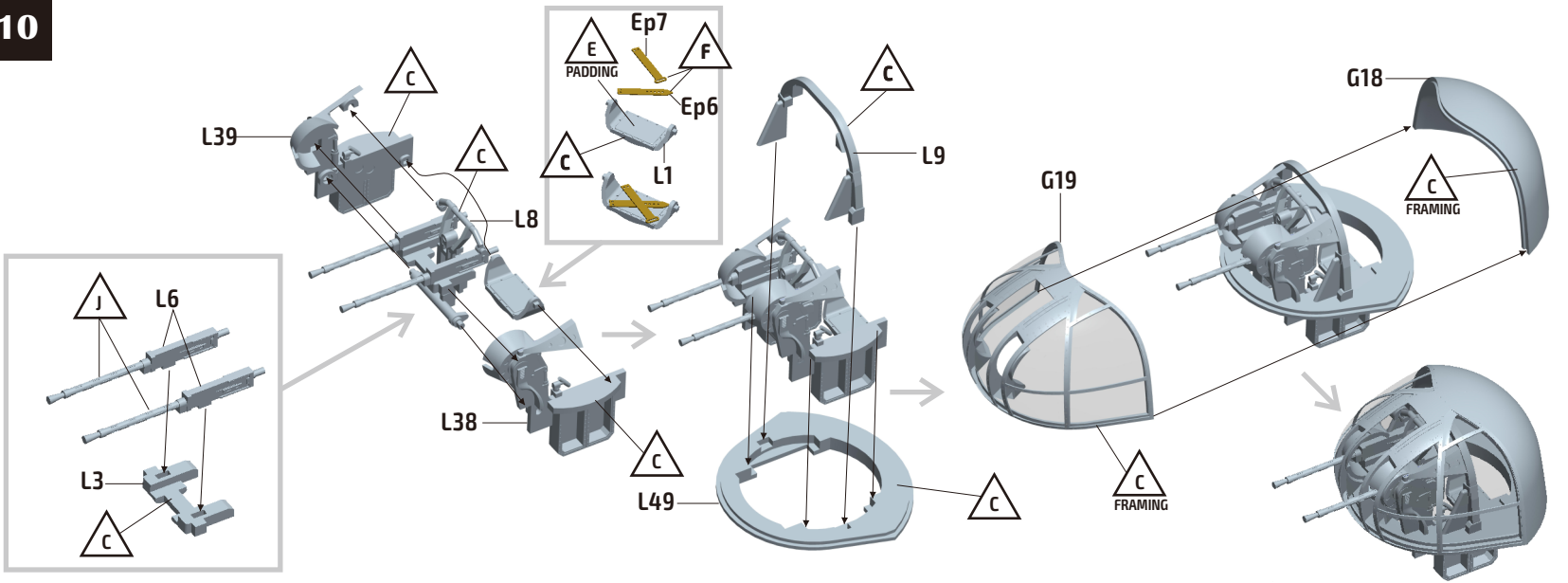

**11**

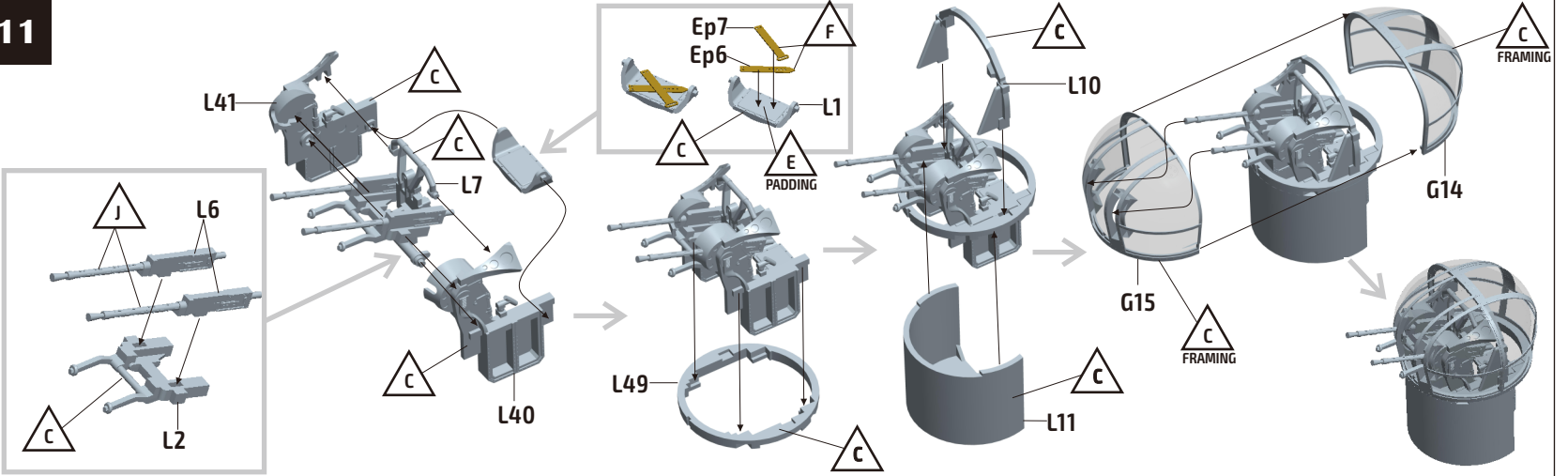

**12**

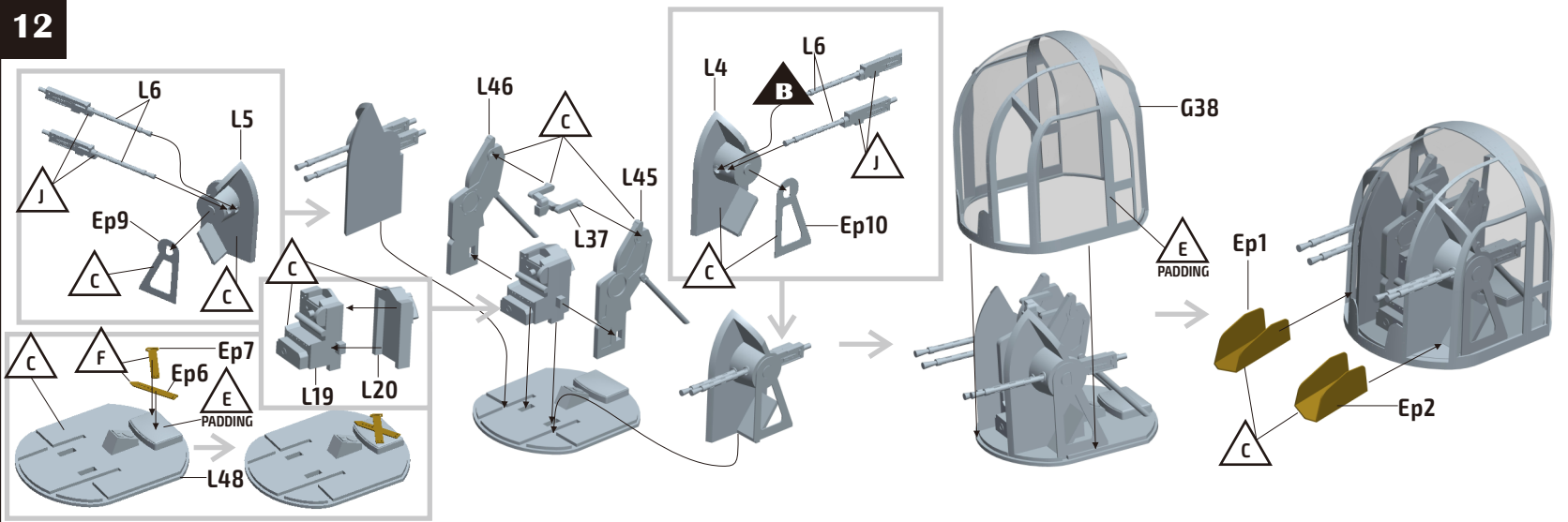

**13**

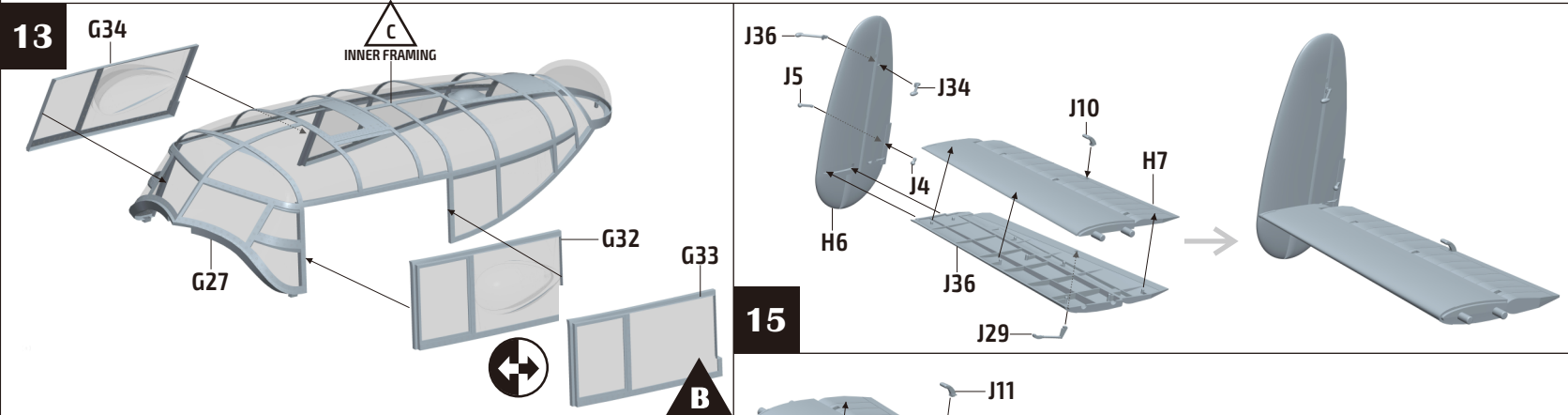

**15**

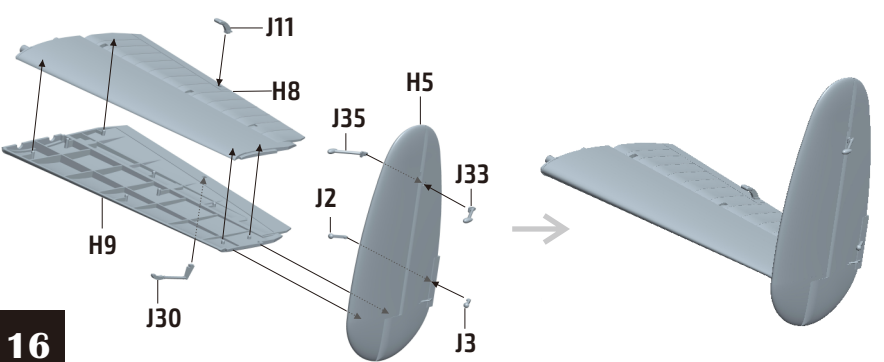

**14**

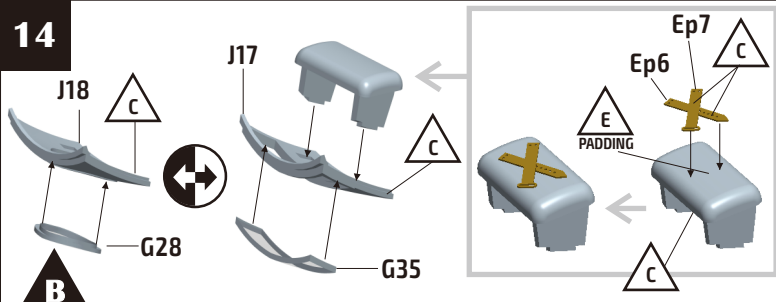

**16**

17-1

17

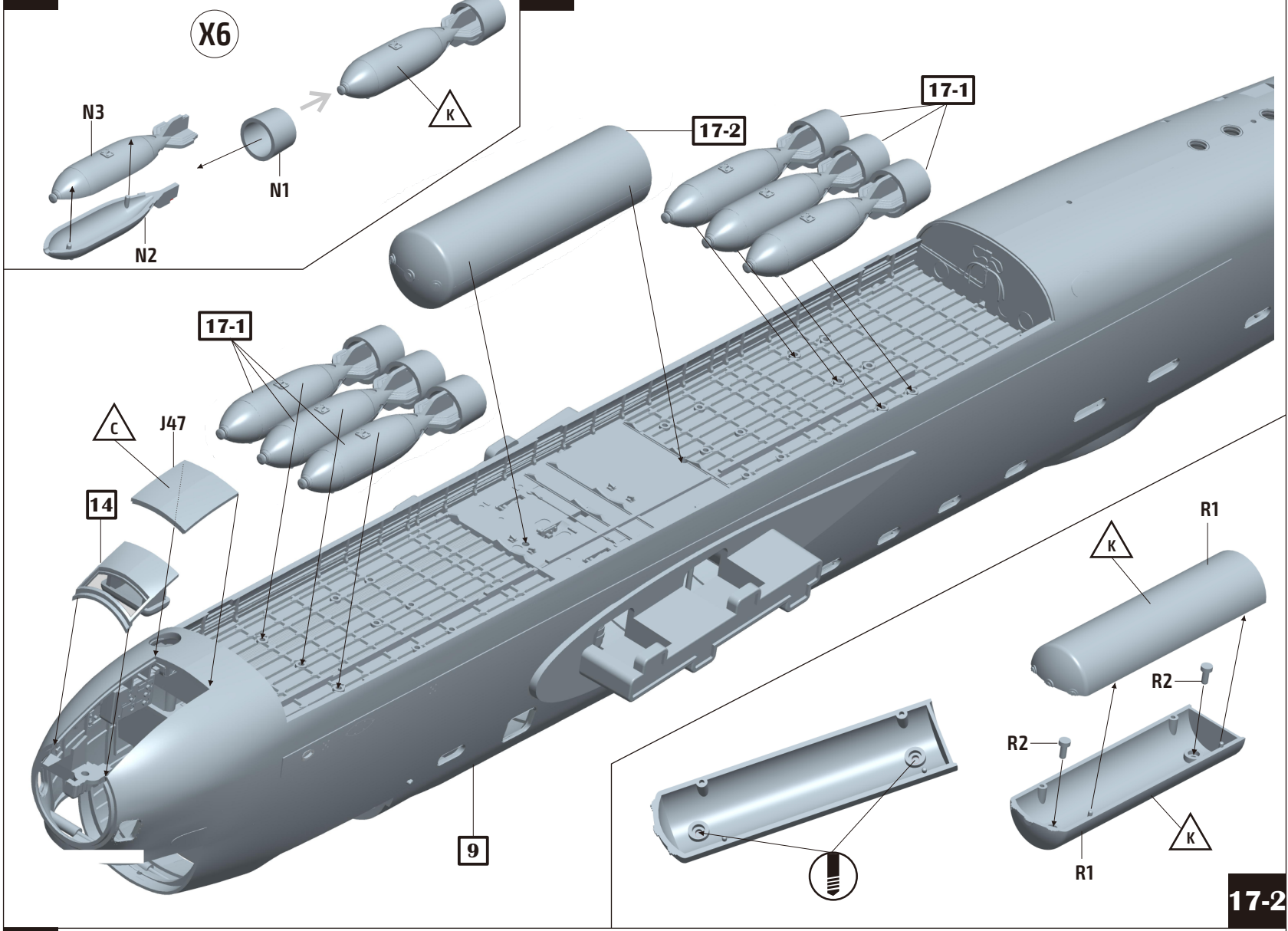

17-2

18

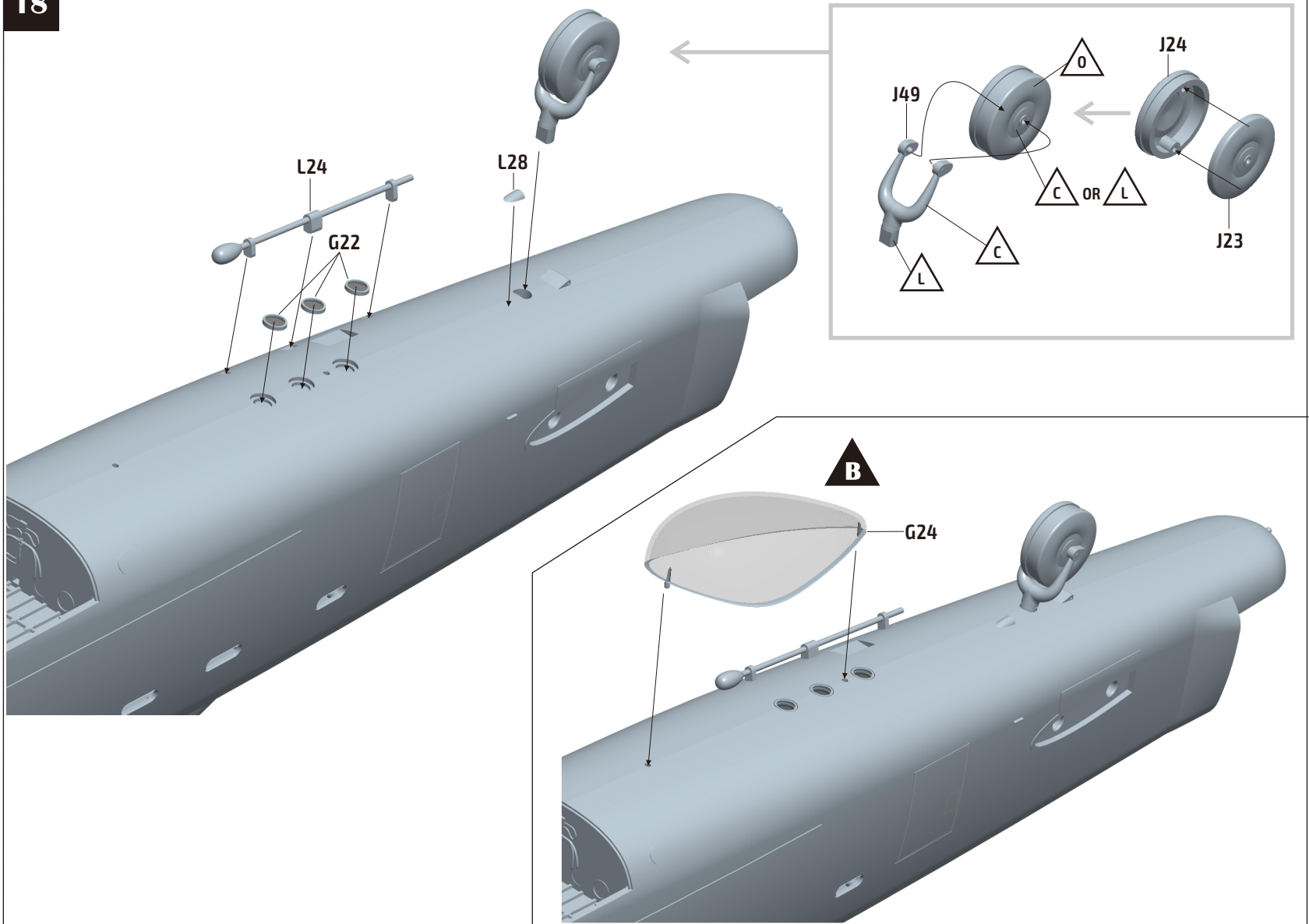

19

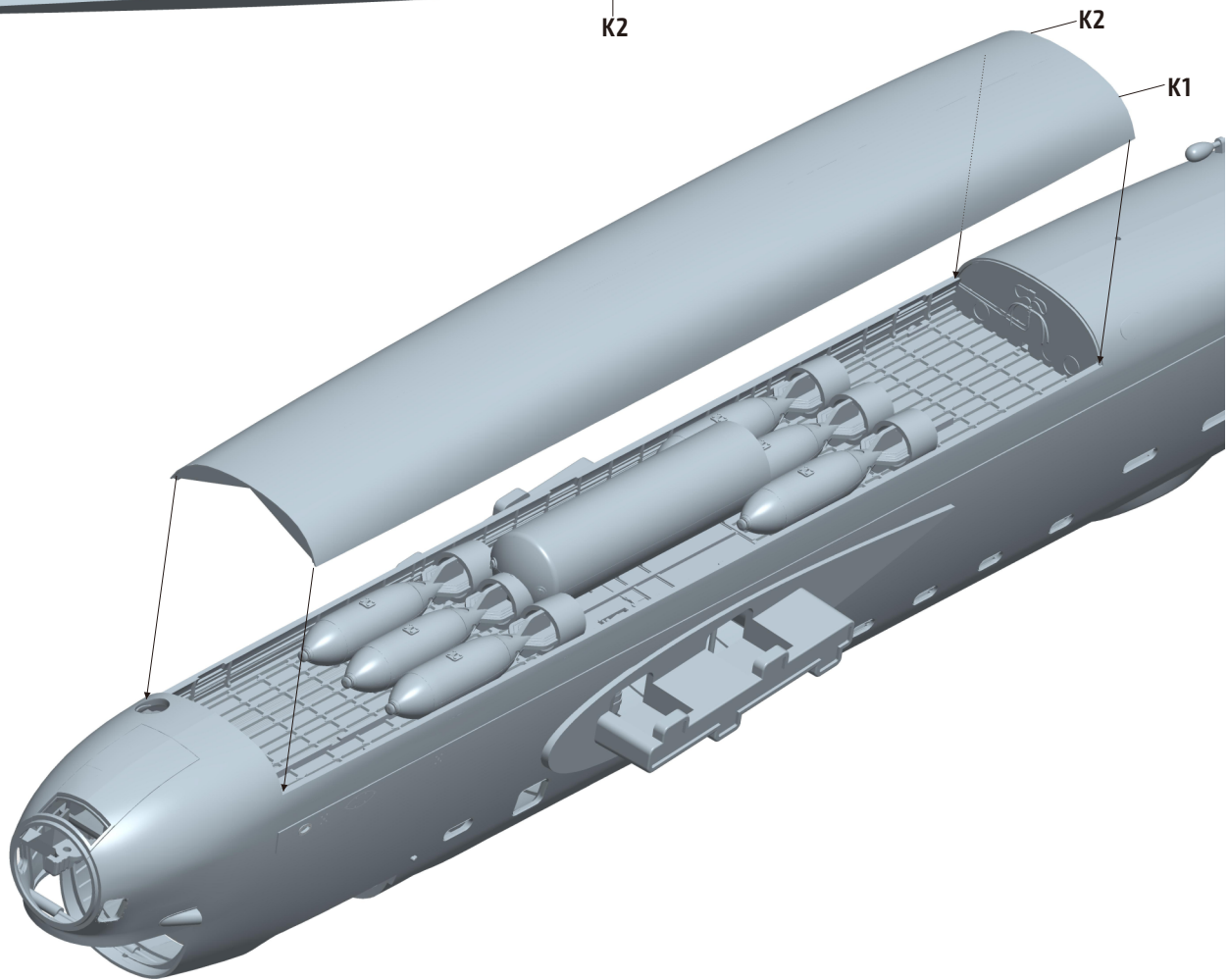
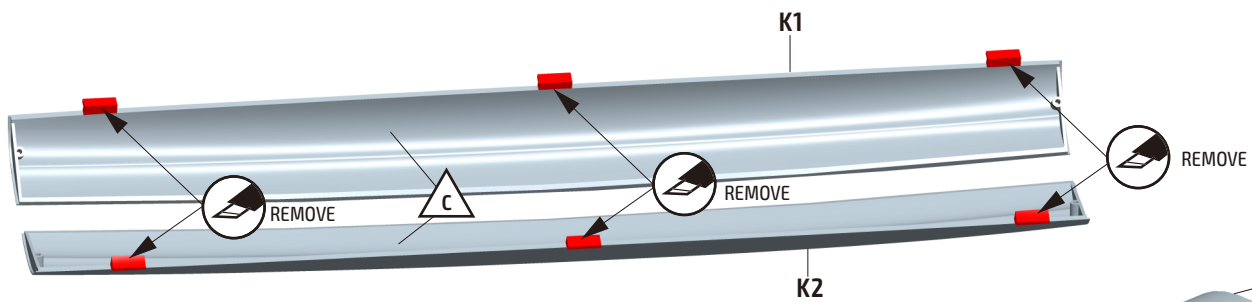

20

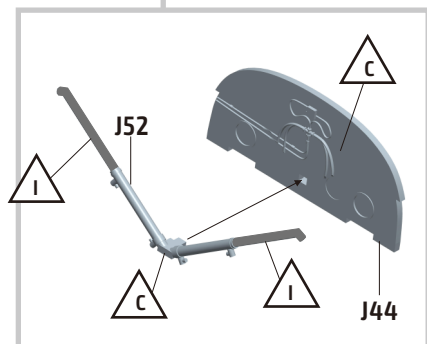
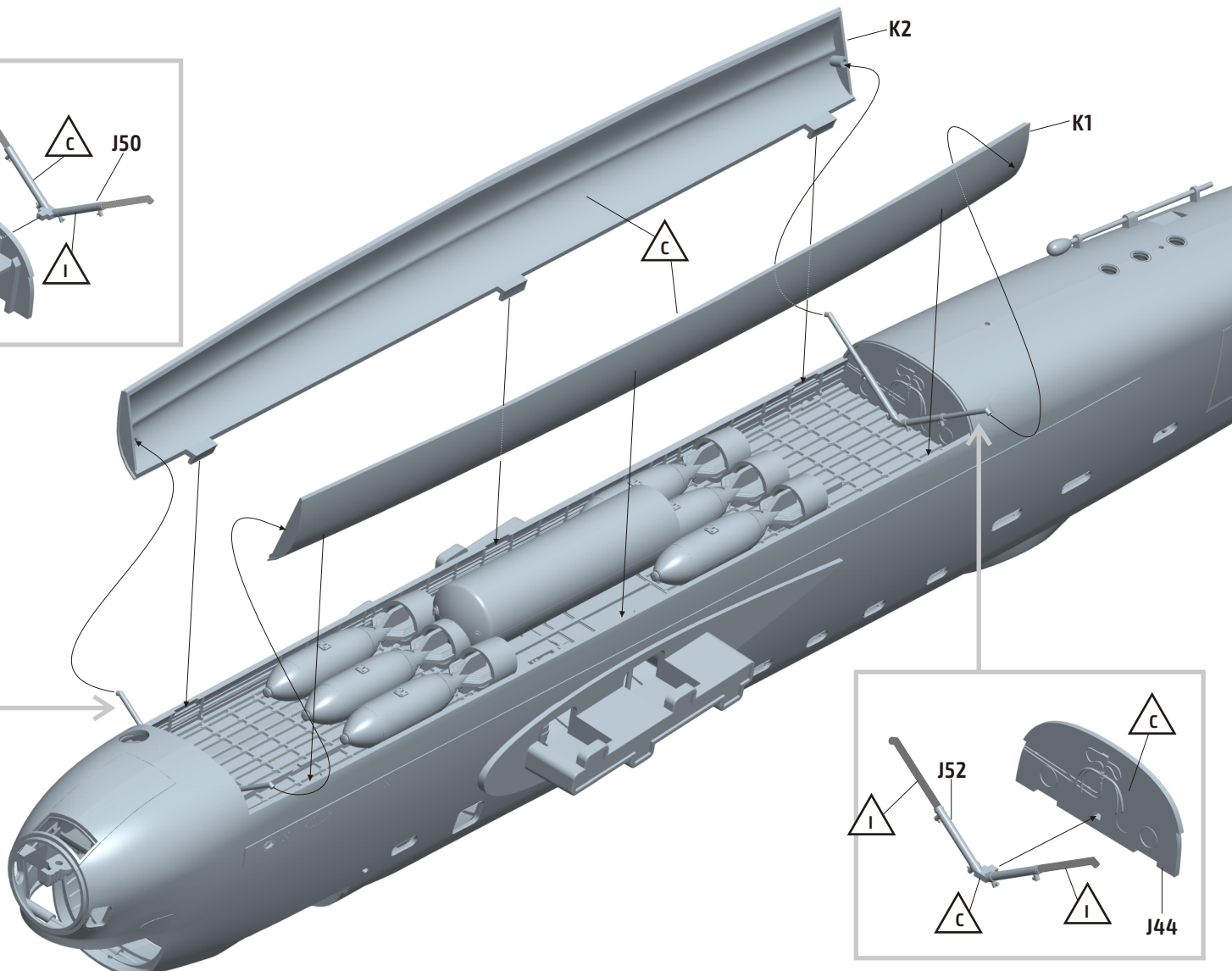
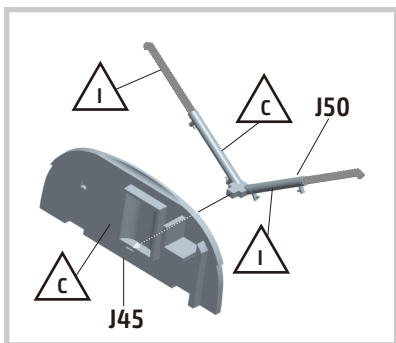

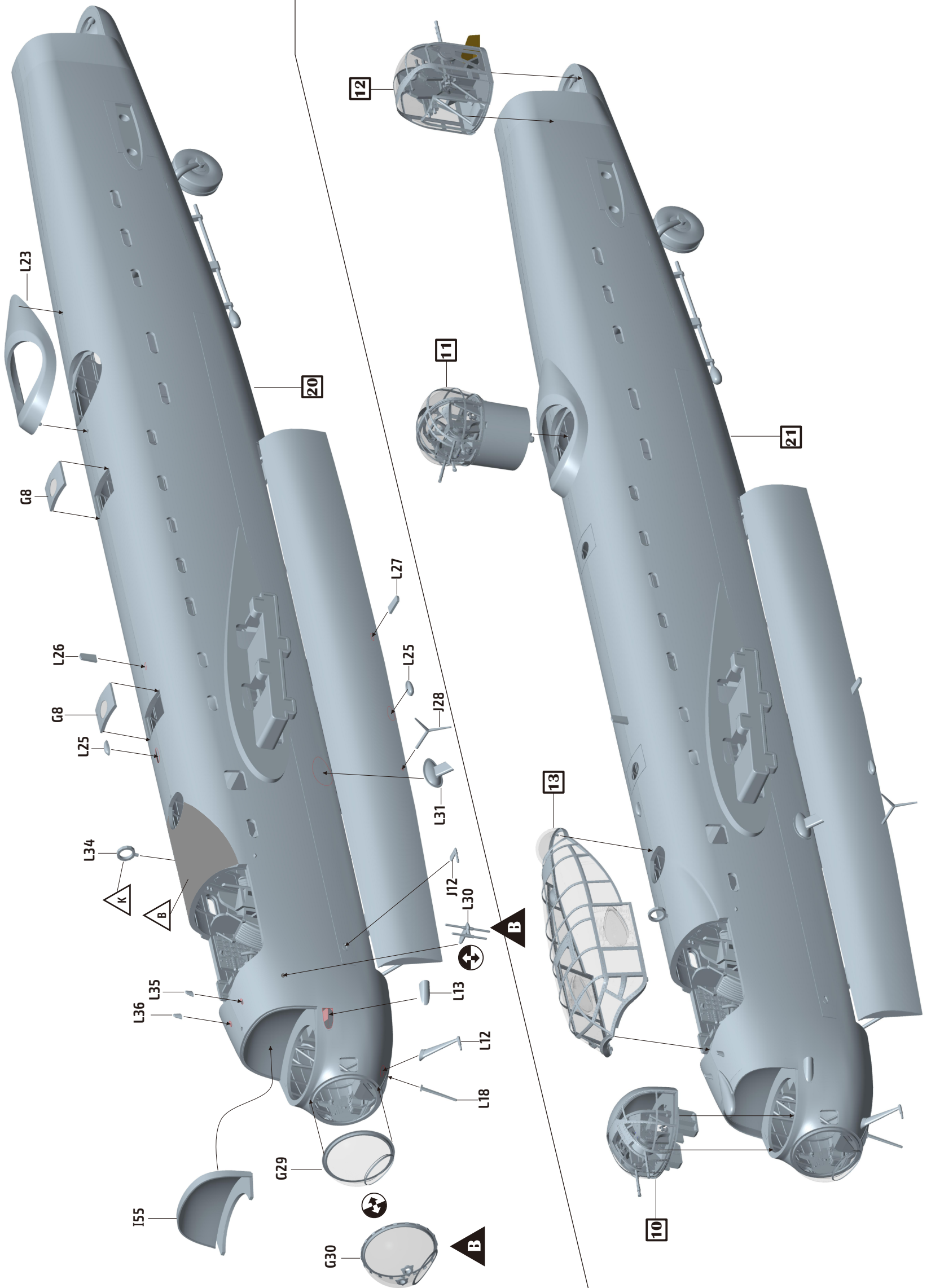



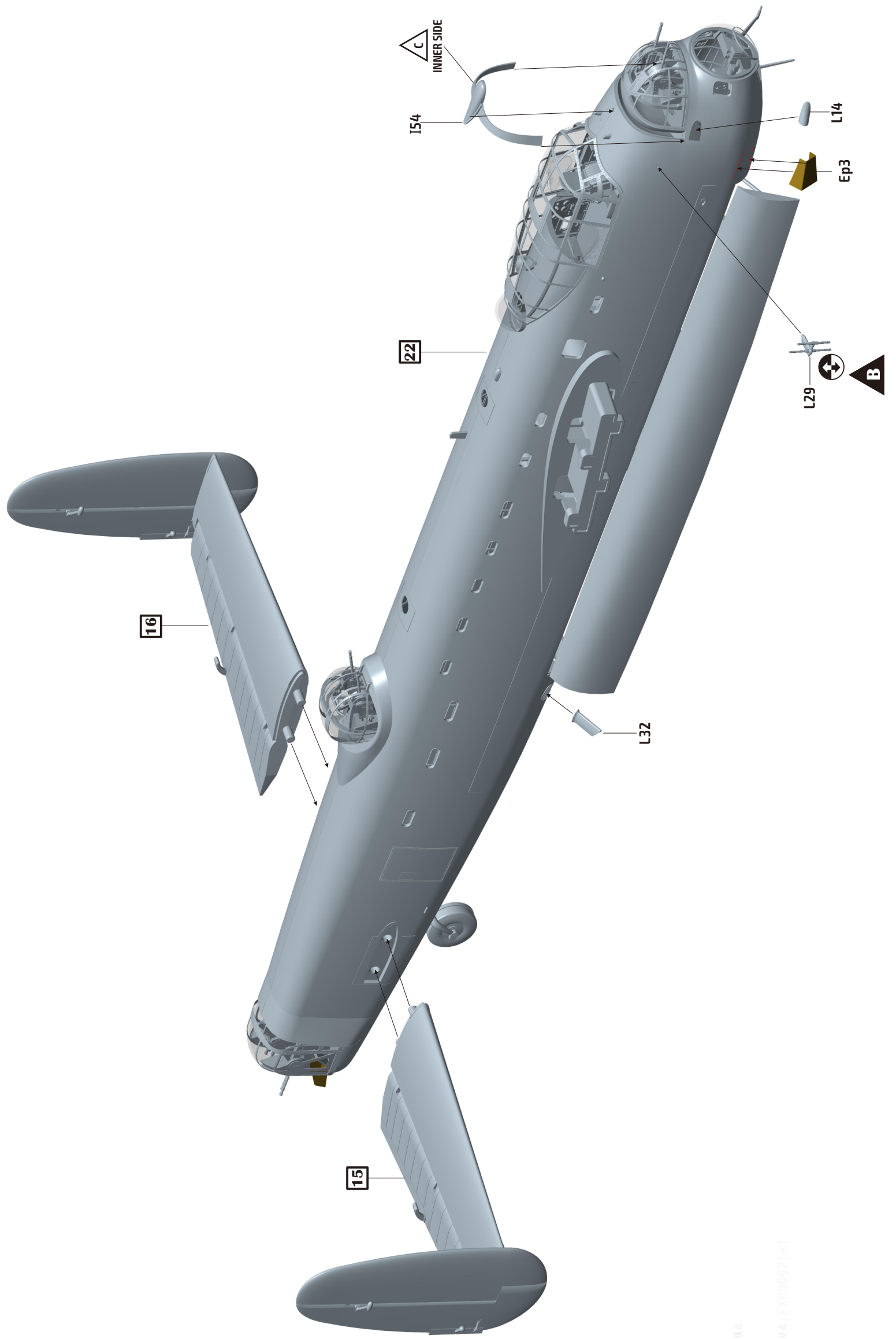

模式

增色: EXP0002(+)

24

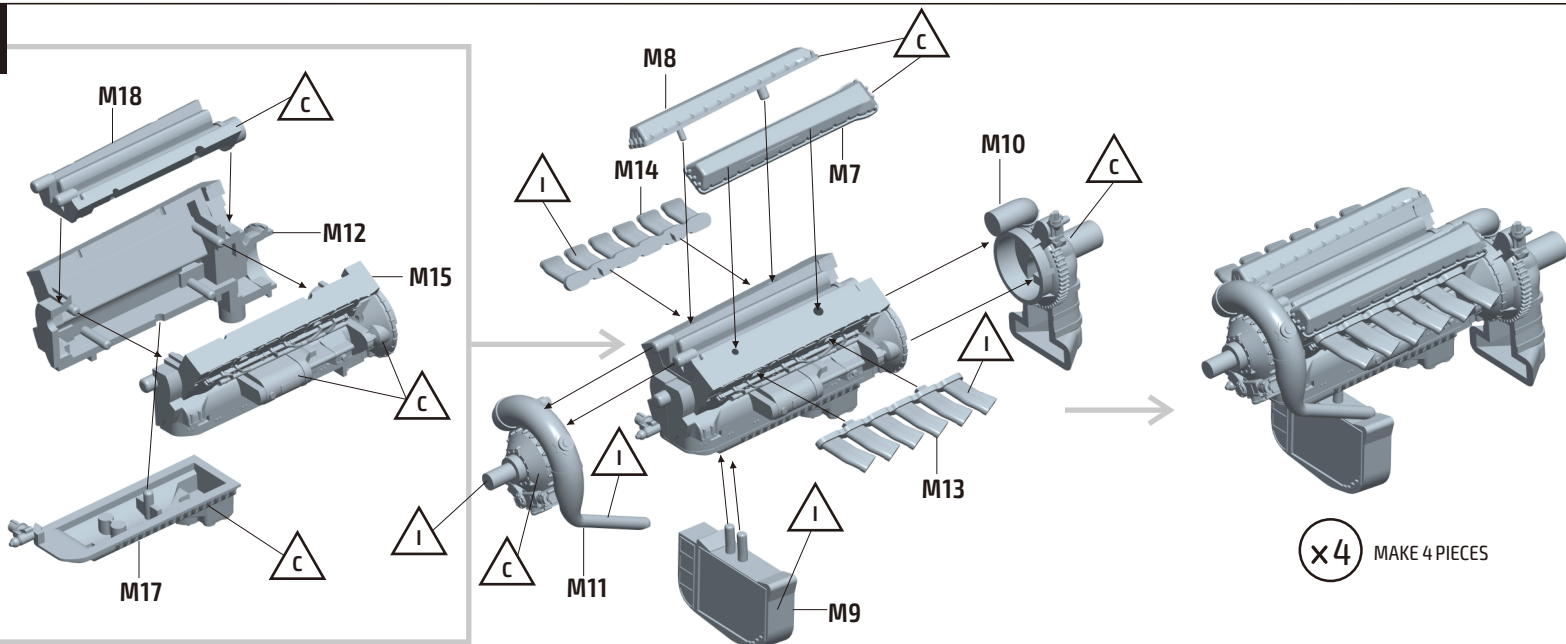

25

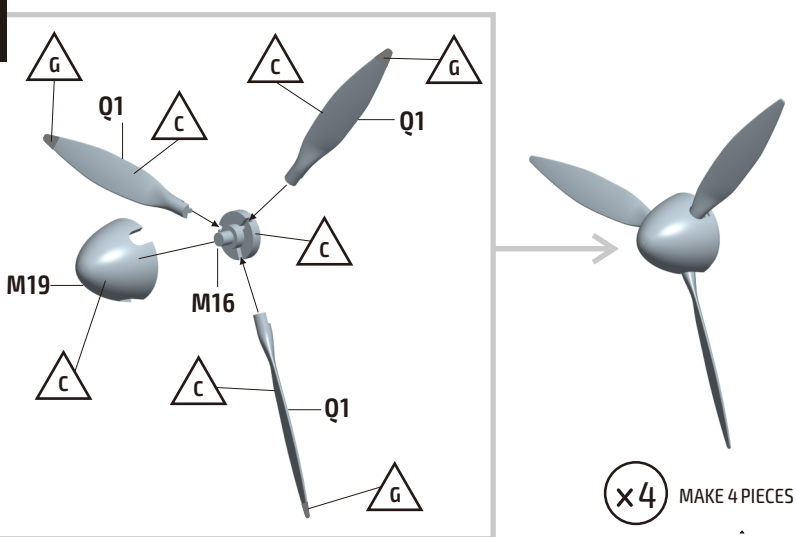

26

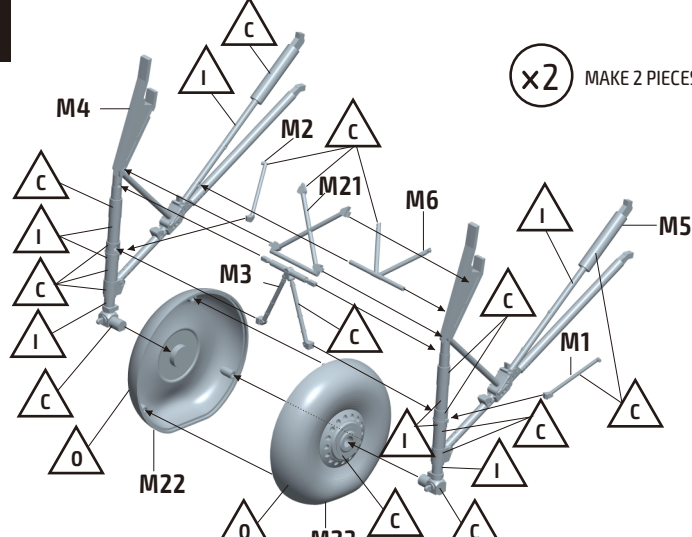

27

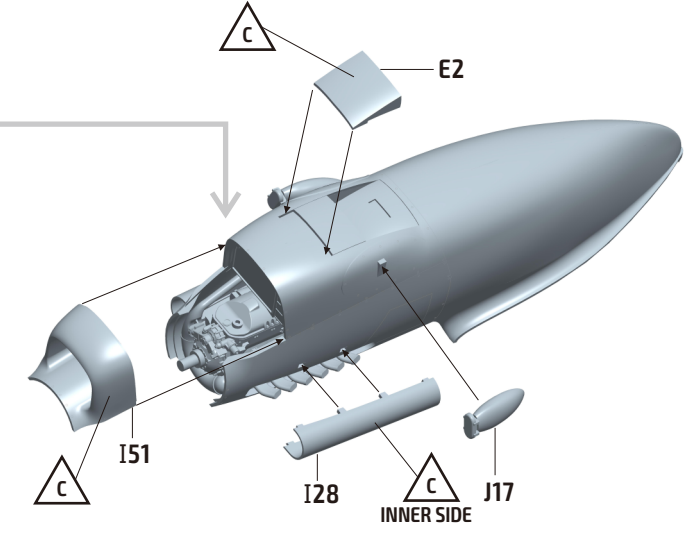
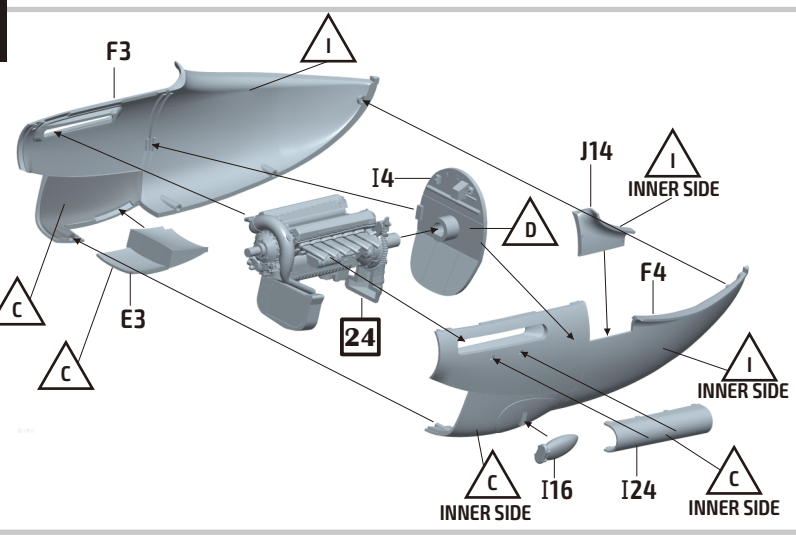

28

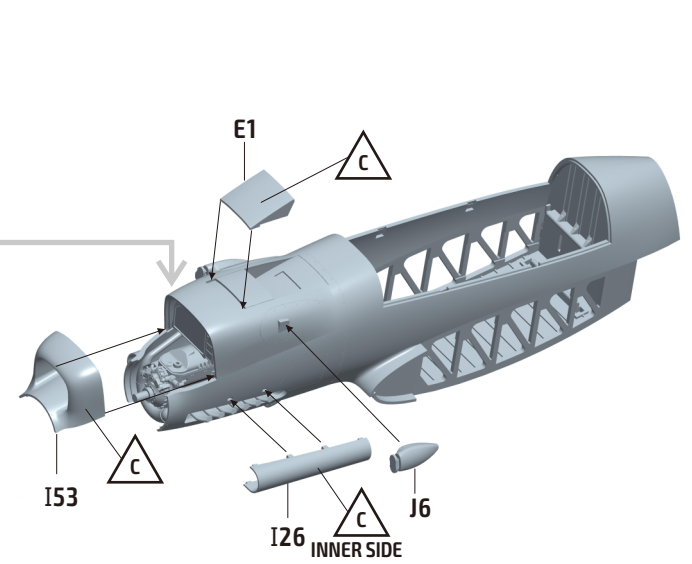
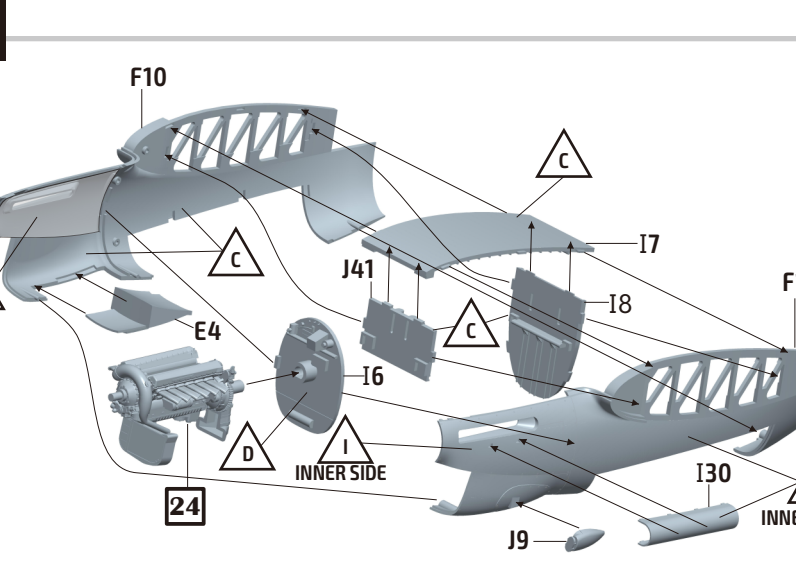

29

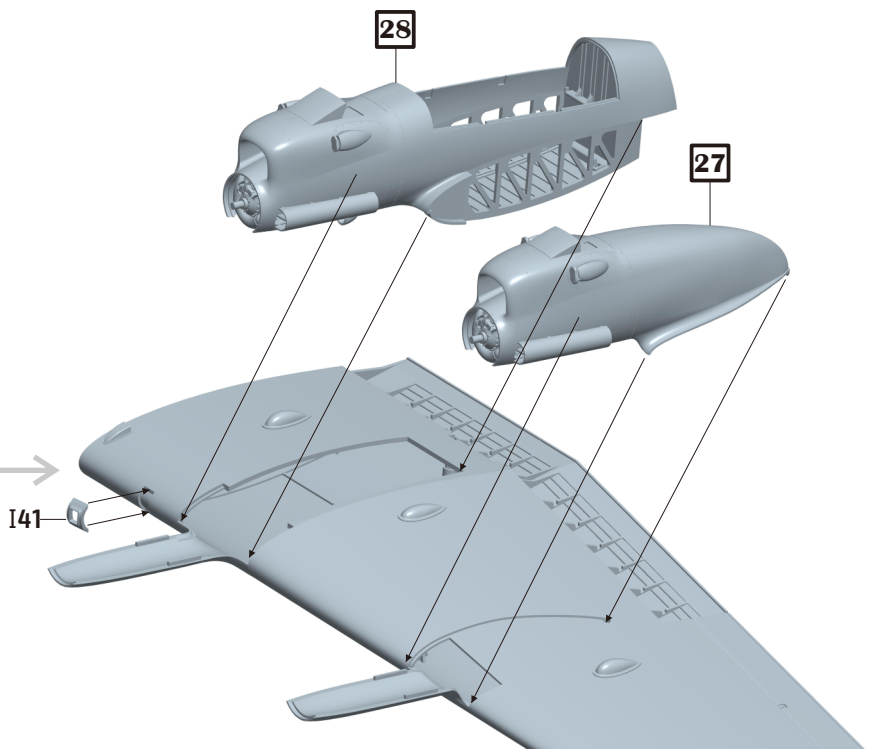
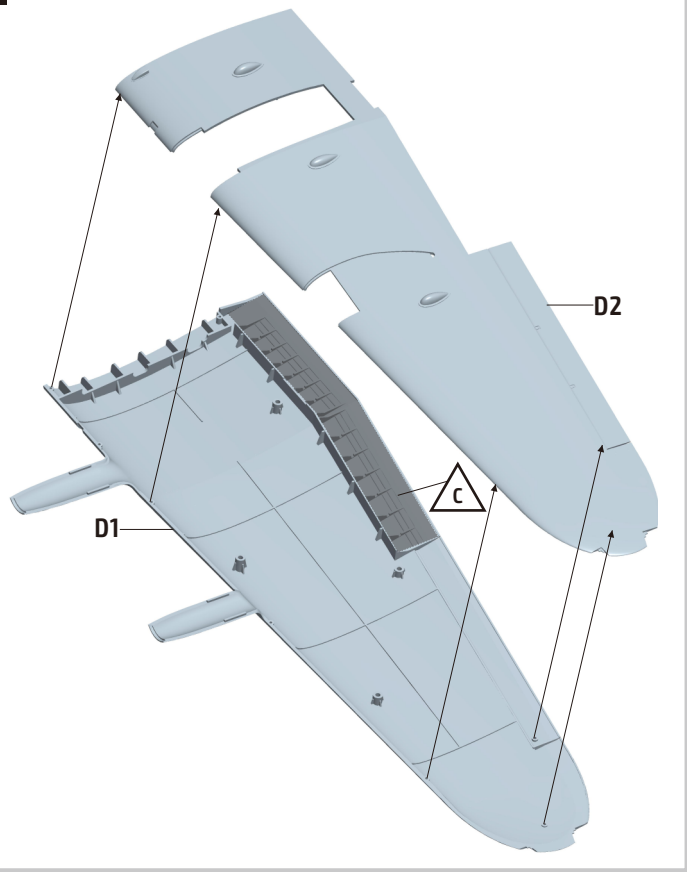

30

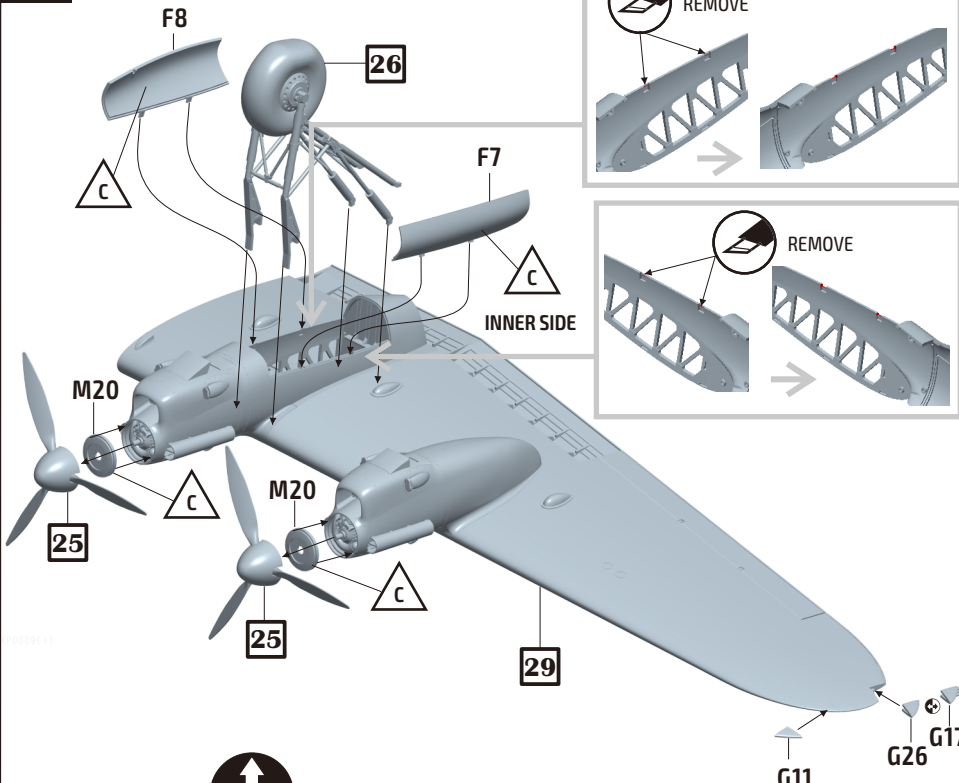

32

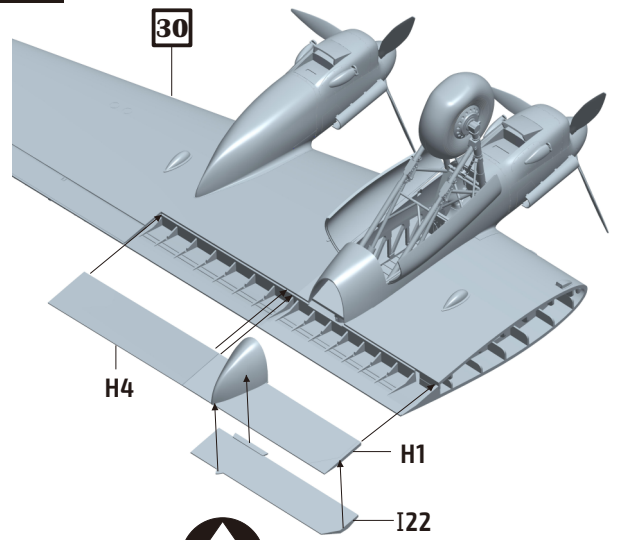

31

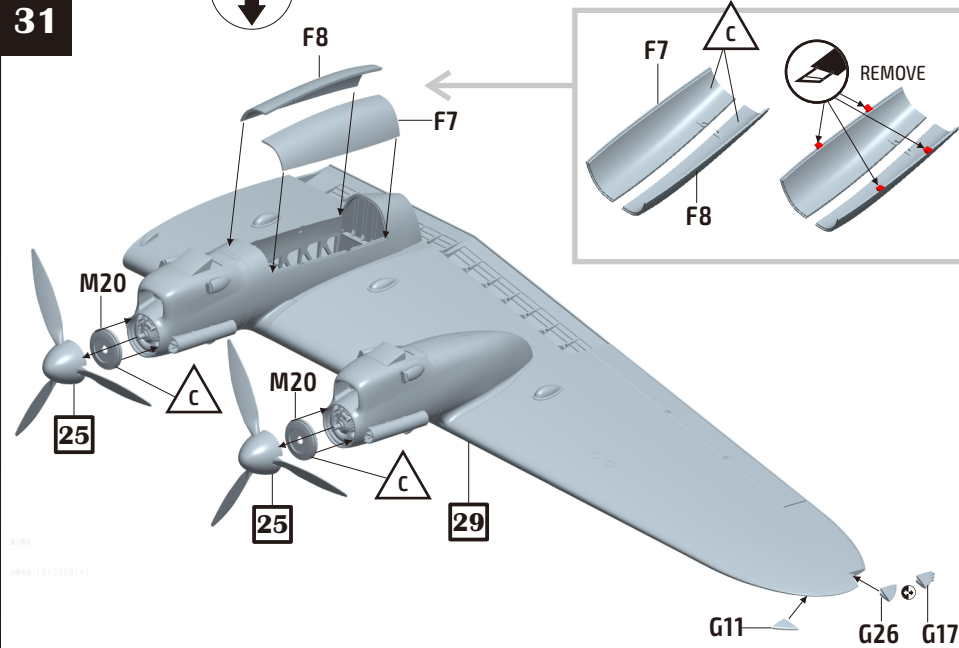

33

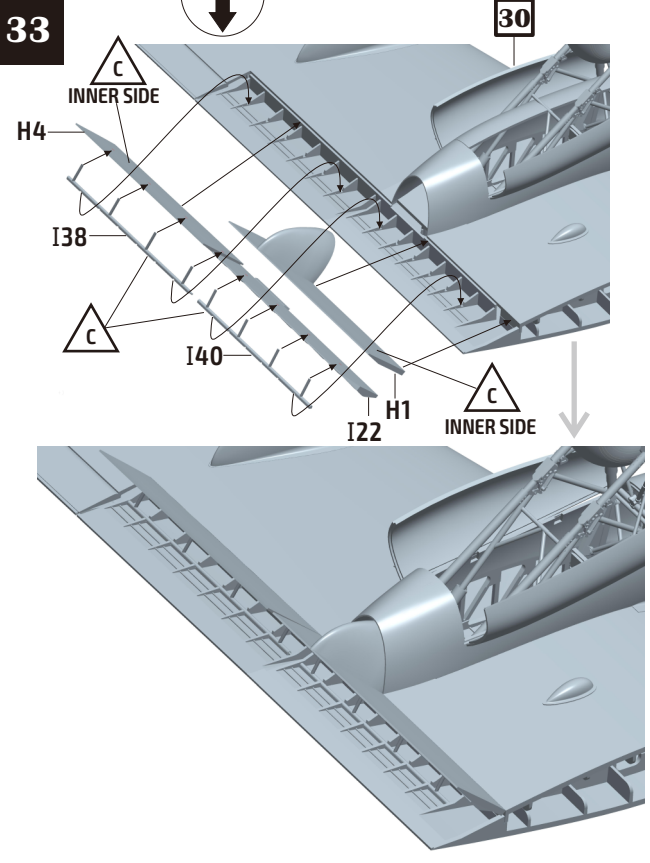

34

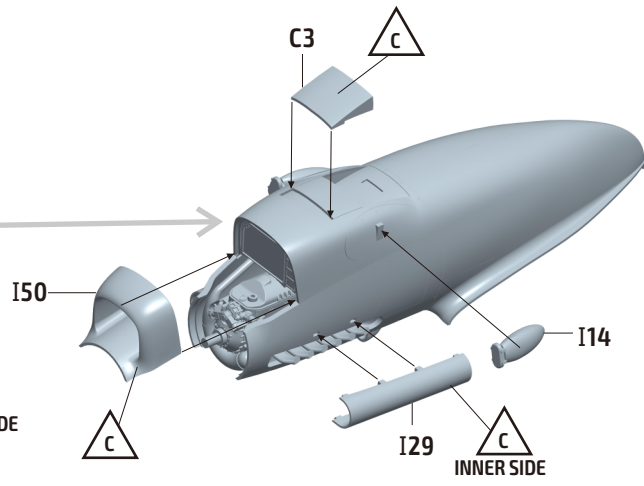
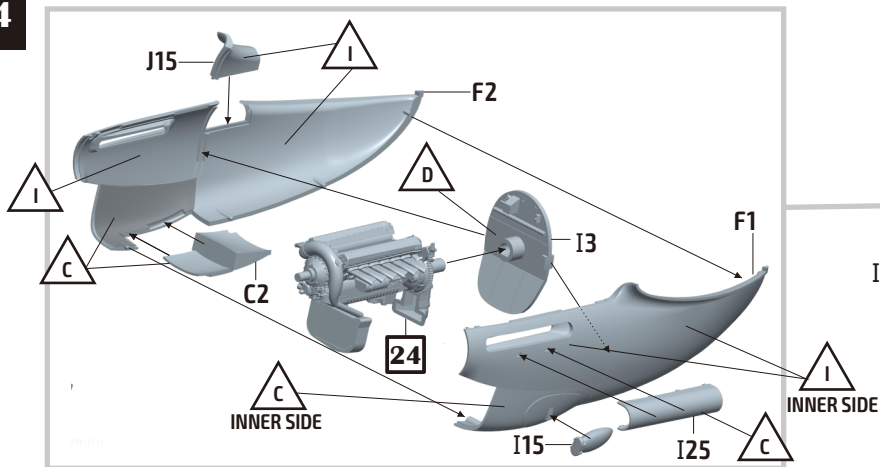

35

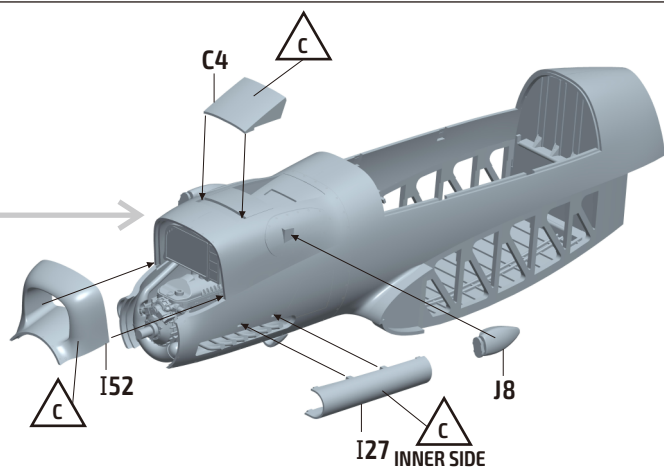
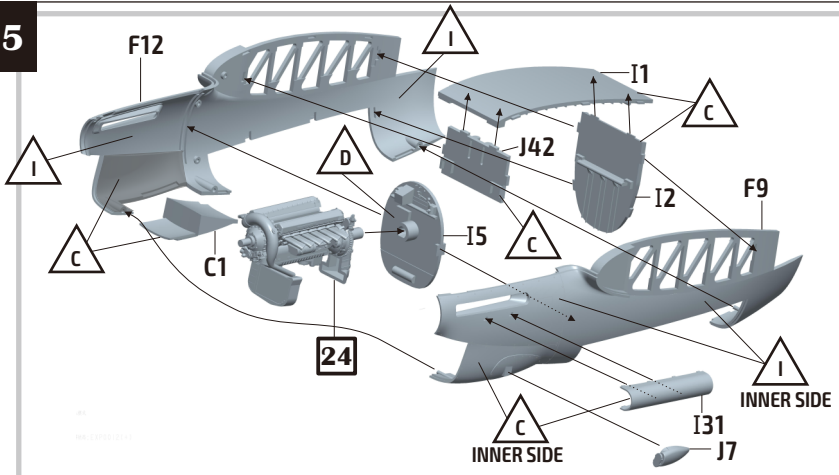

36

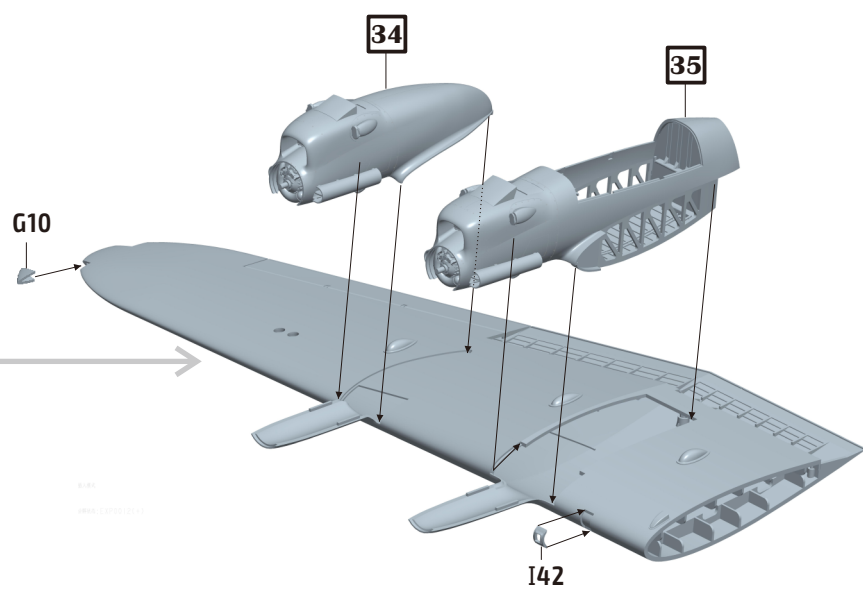
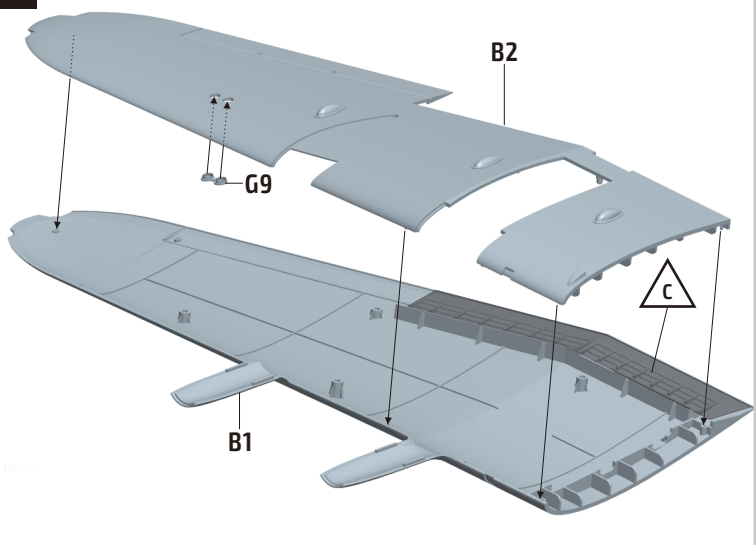

37

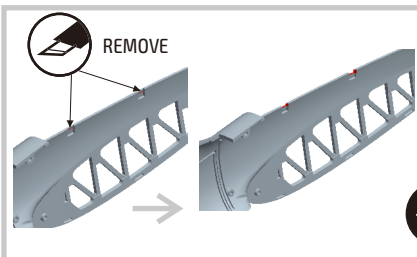
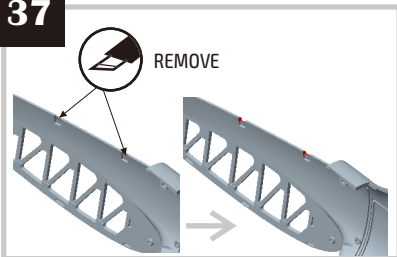

38

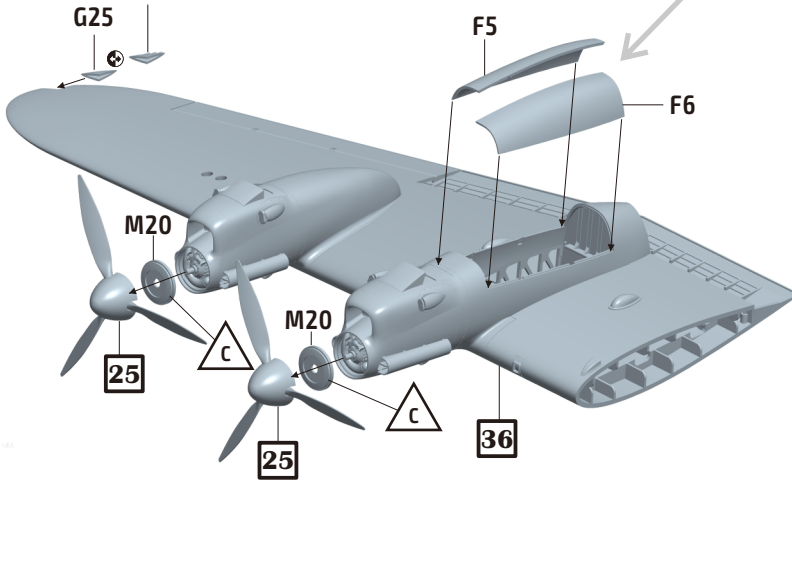
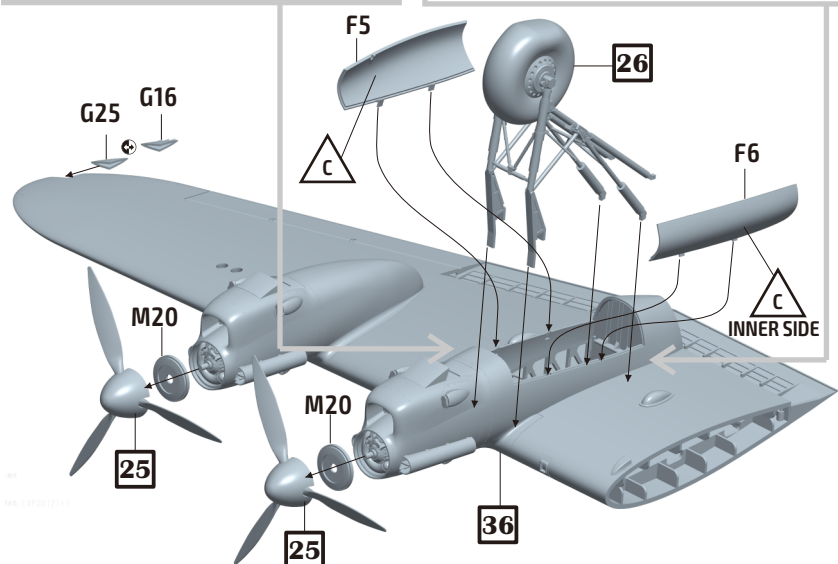
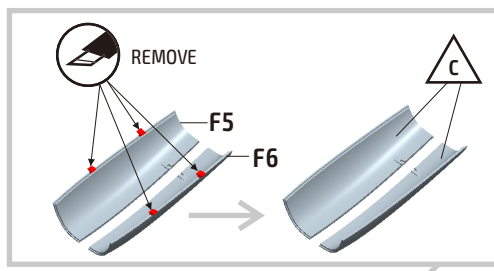

39

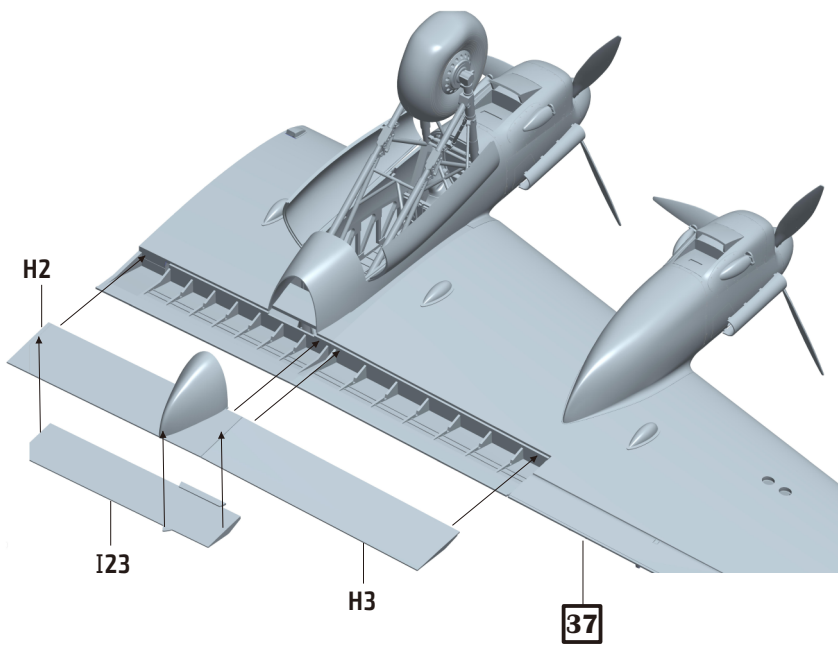

40

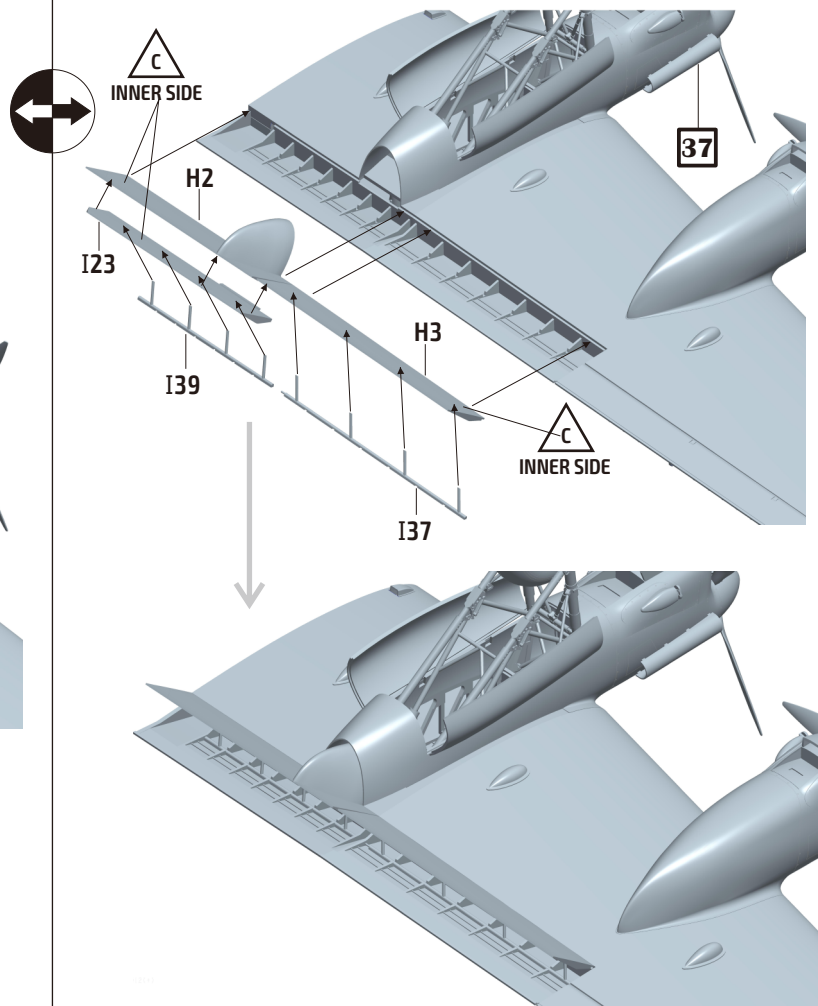

41

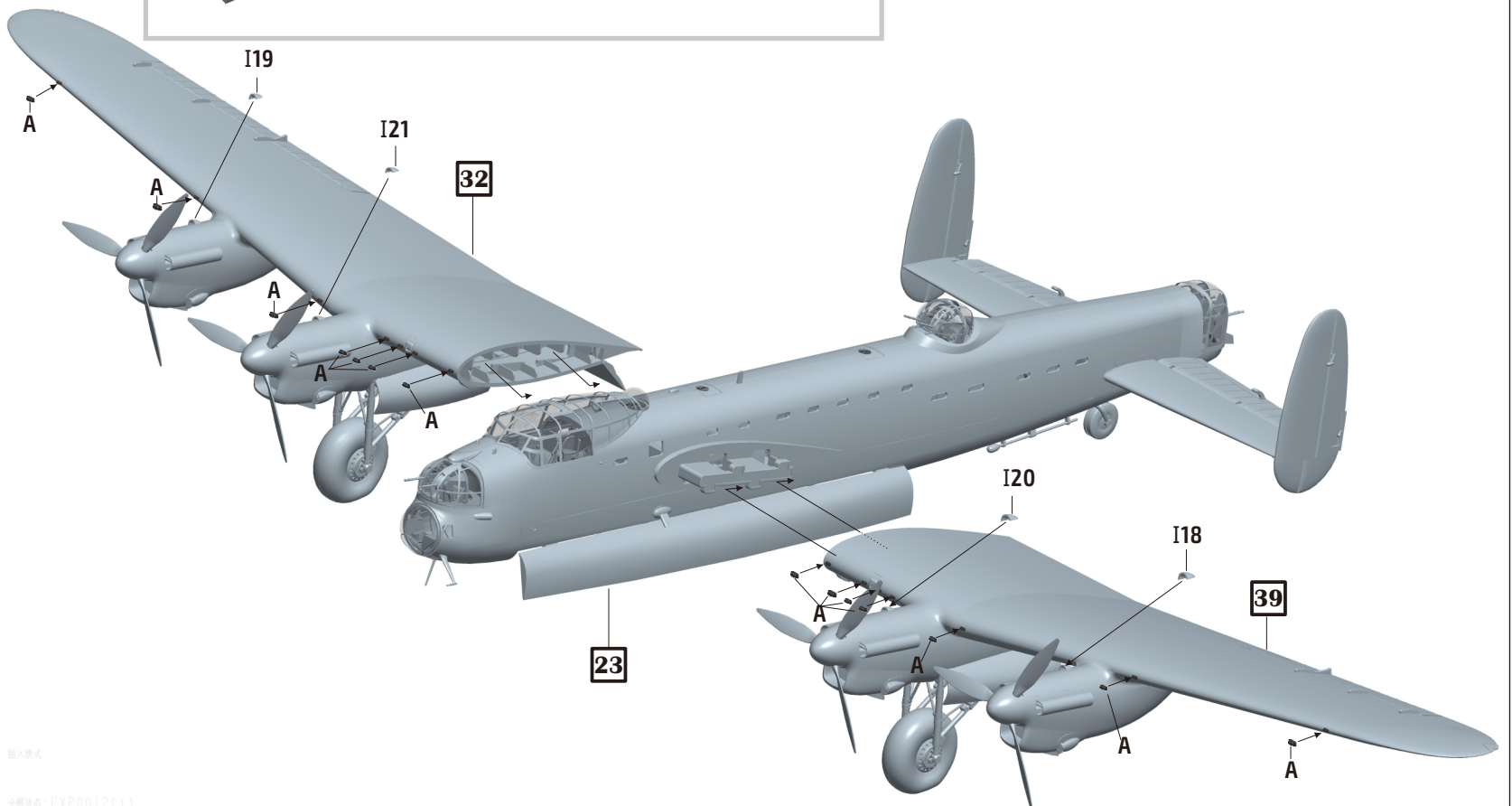
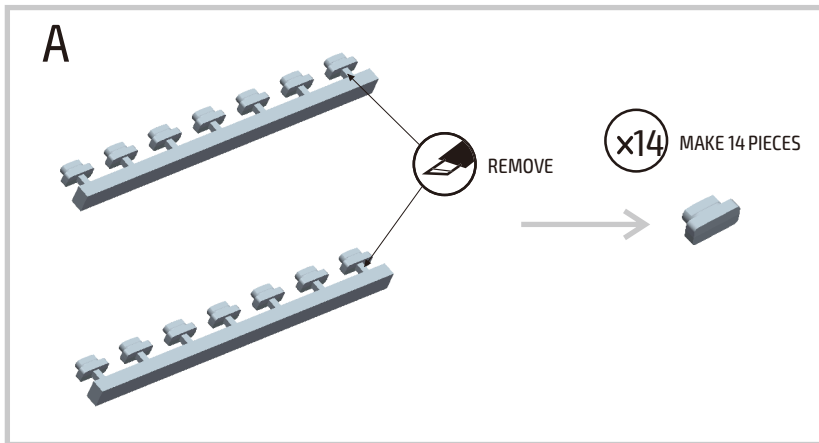

HK MODELS  
#HK4:EXP0012(+)



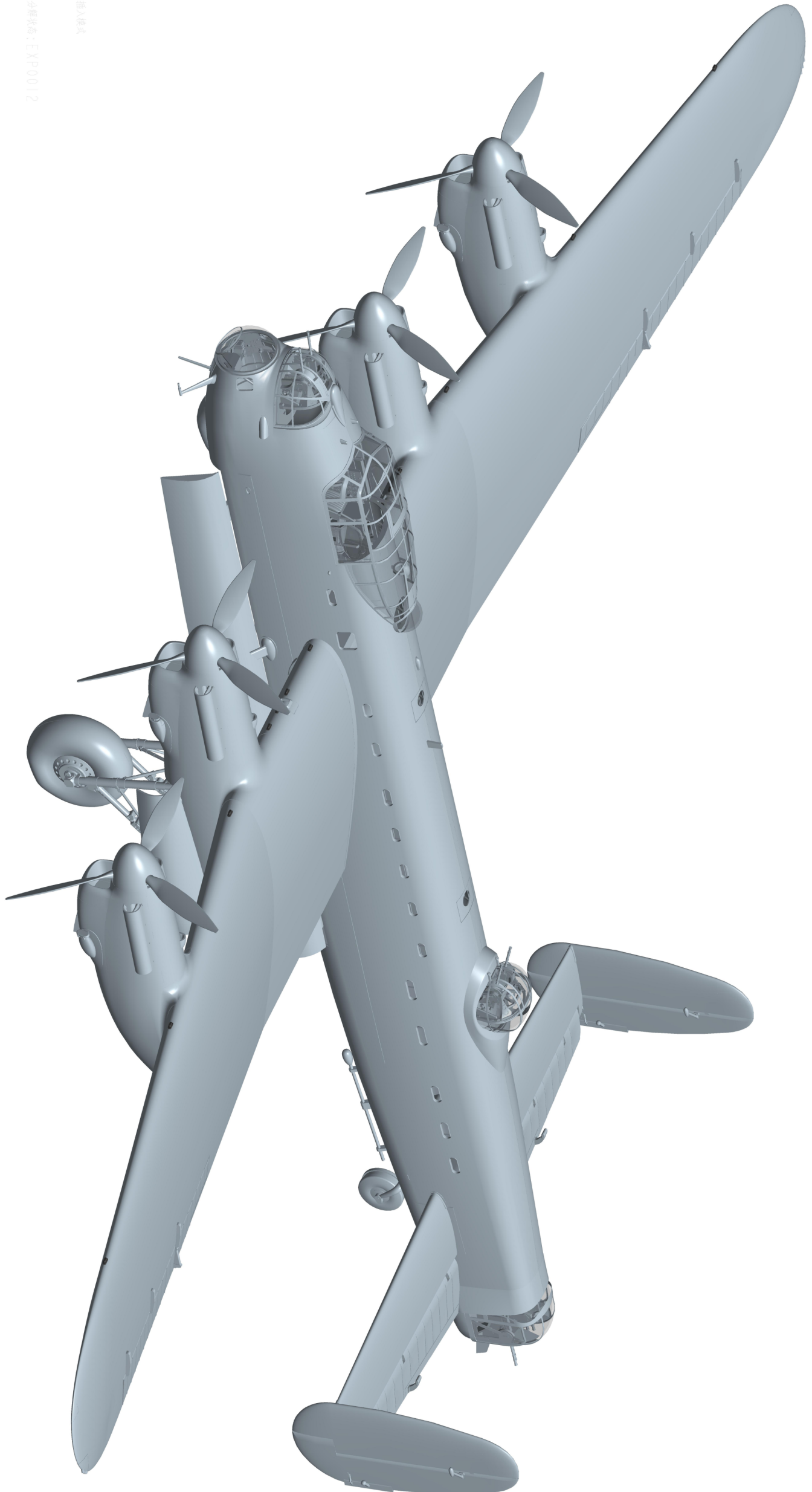

# Parts

A1

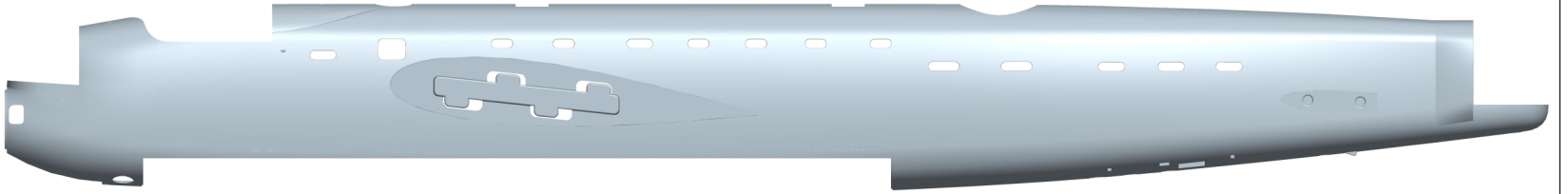

A2

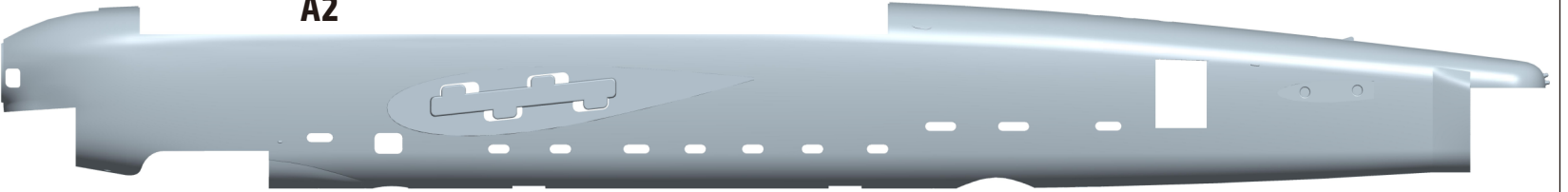

B2

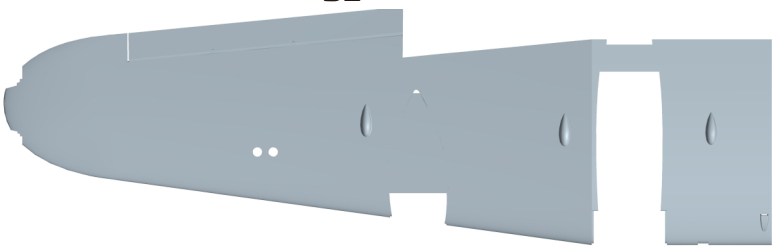

D1

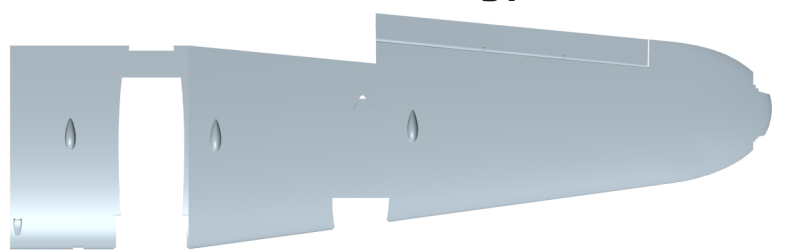

B1

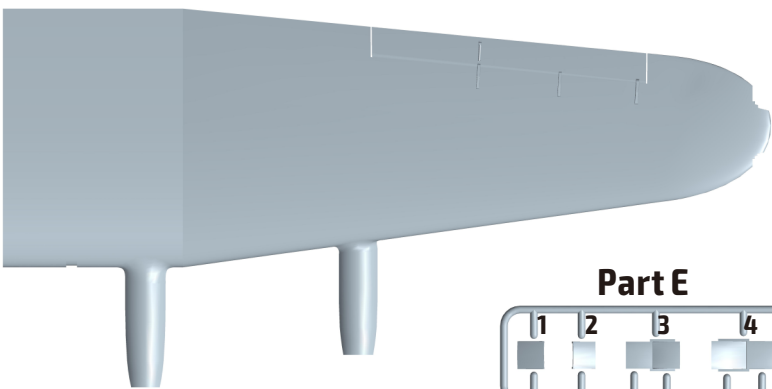

D2

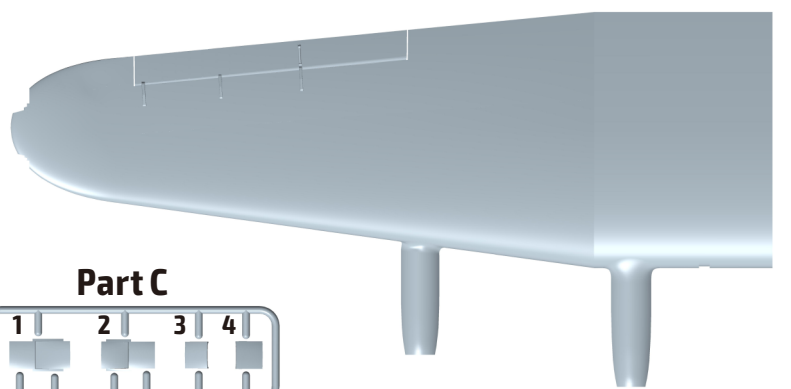

Part E

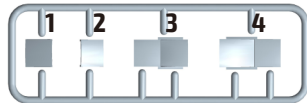

Part C

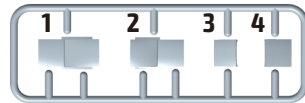

Part F

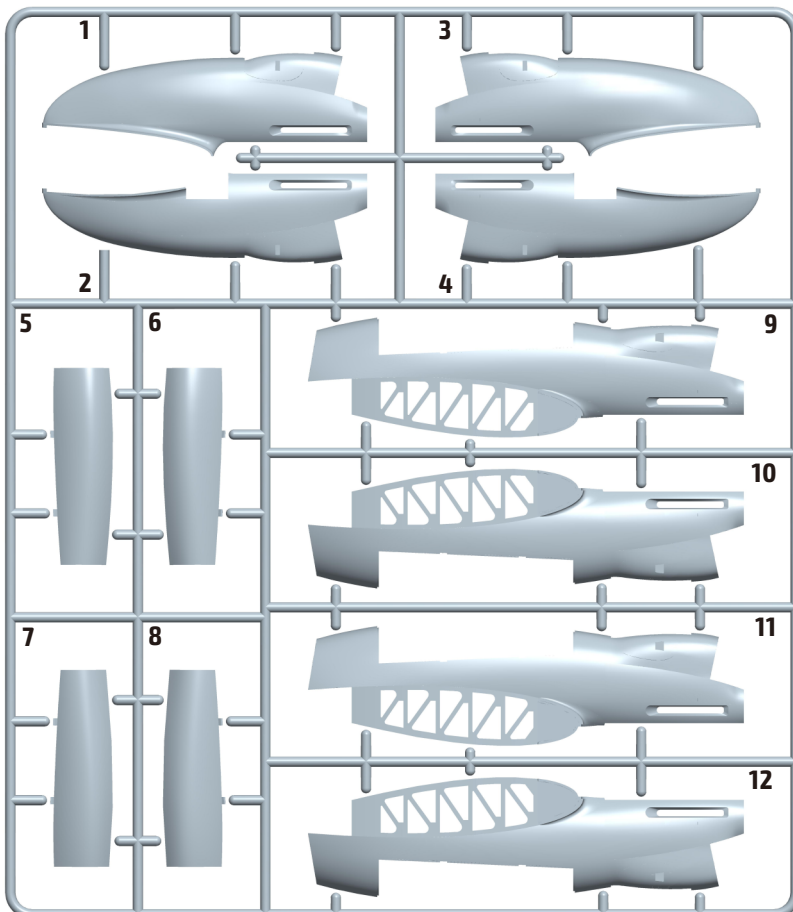

Part H

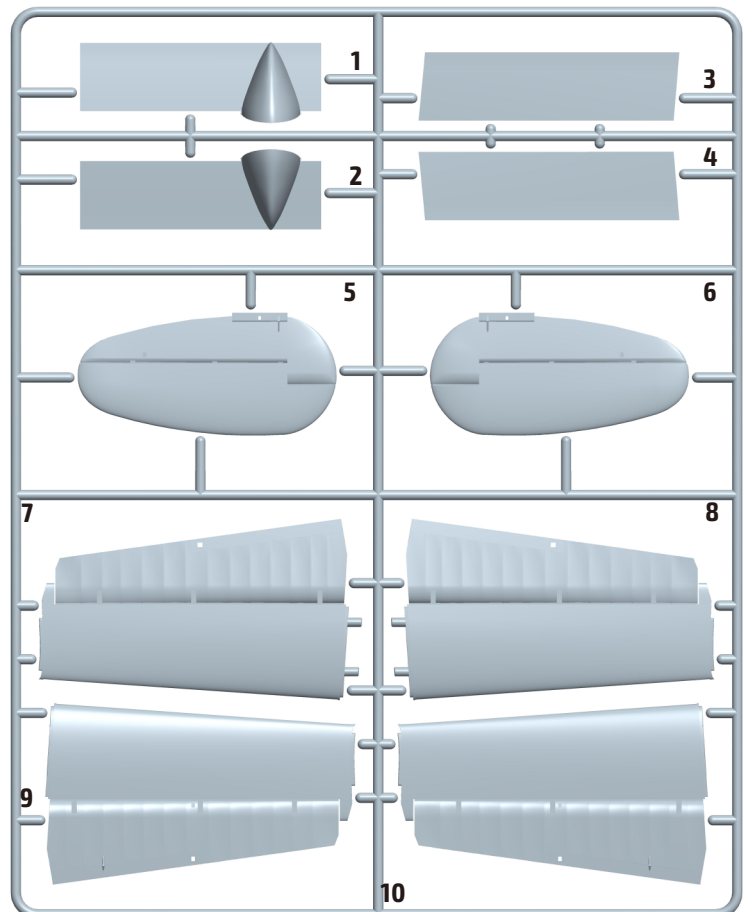

# Parts

## Part I

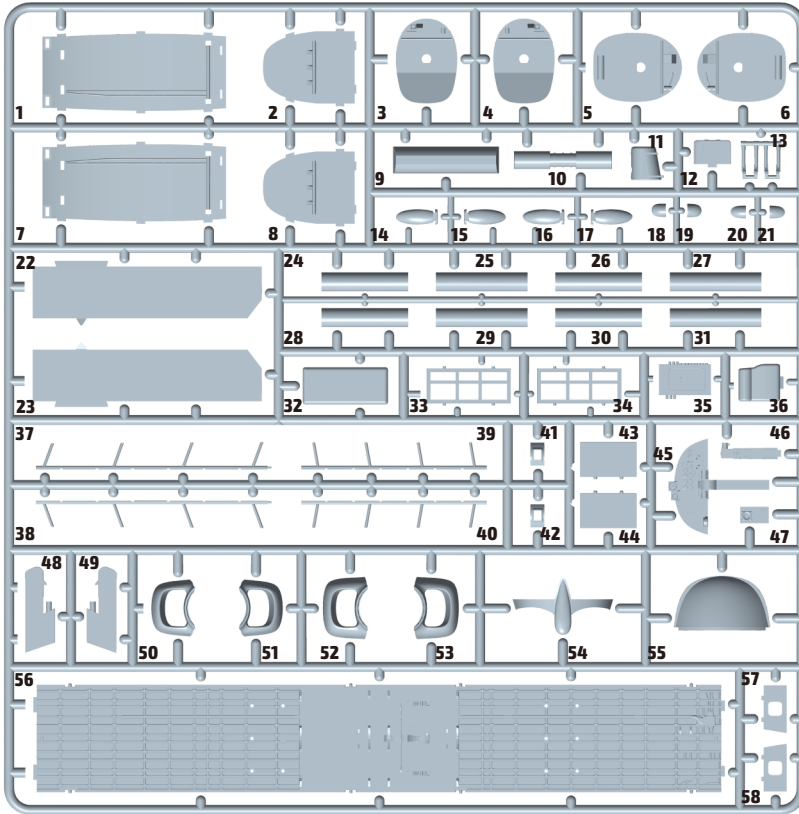

## Part J

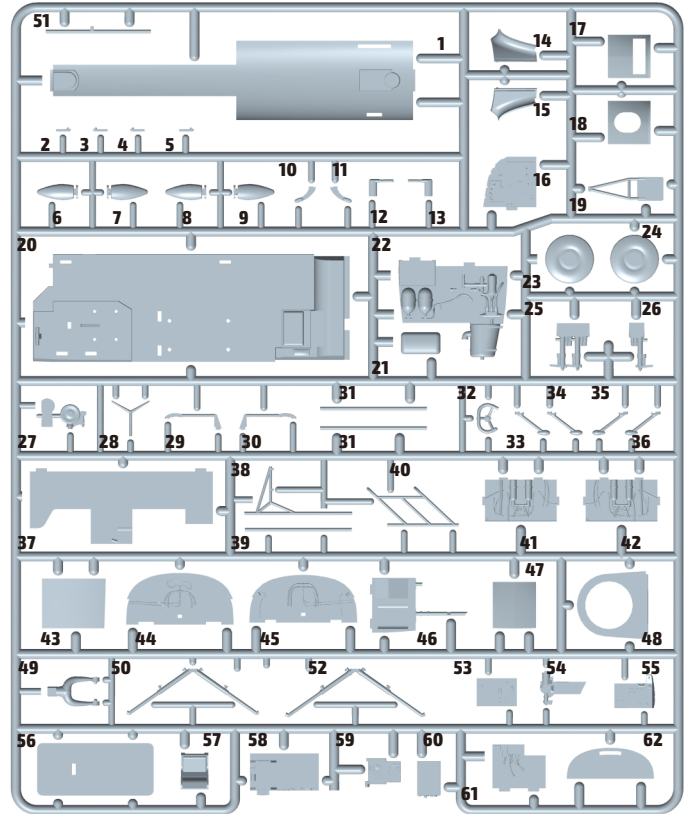

## Part K

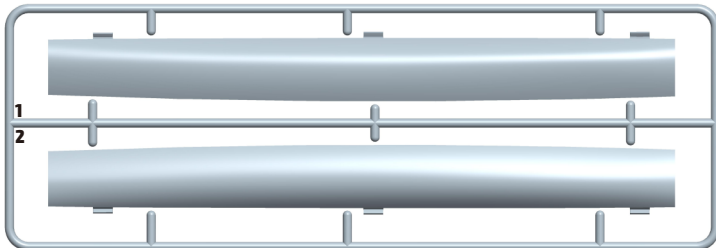

## Part L

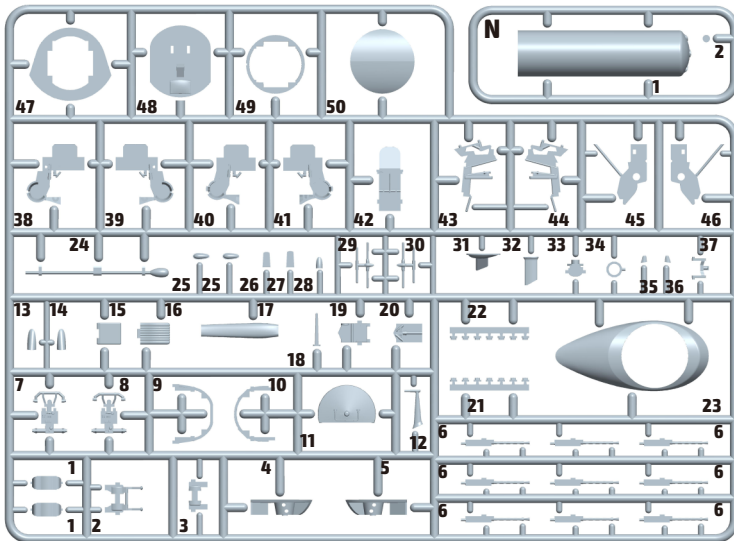

## Part M X2

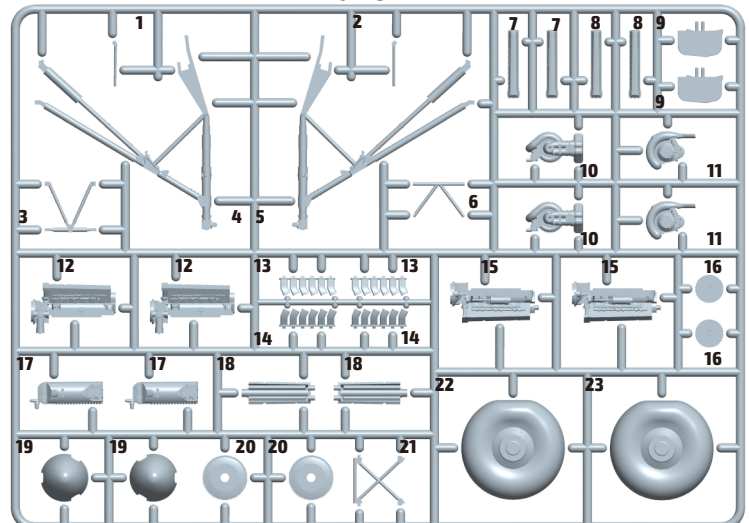

## Part N X2

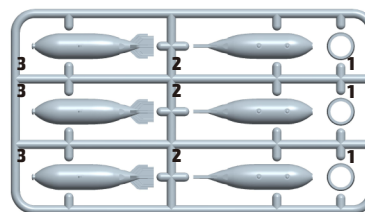

## Part P X2

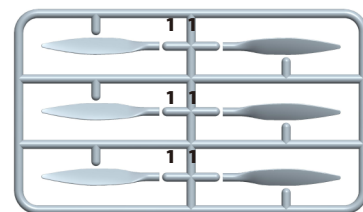

## Part G

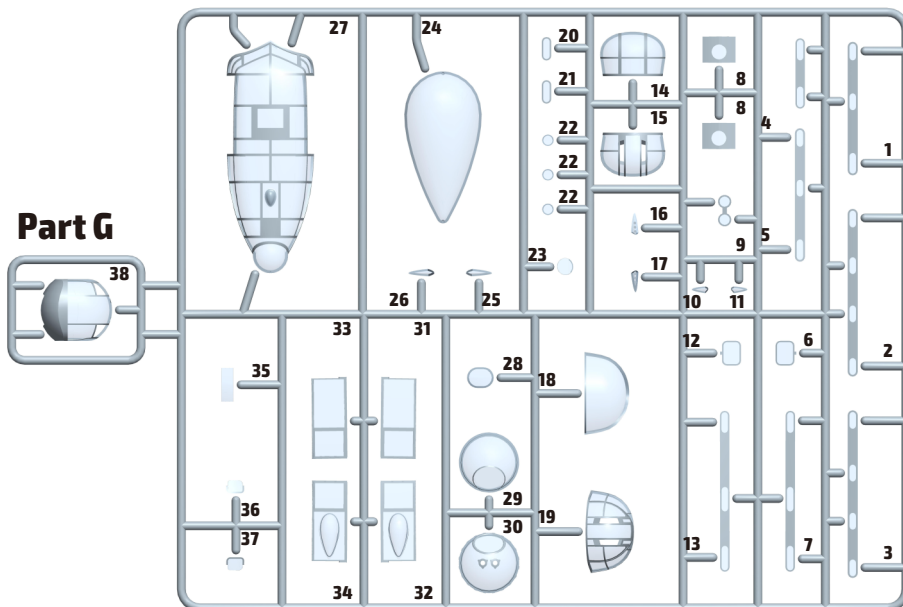

## Part G

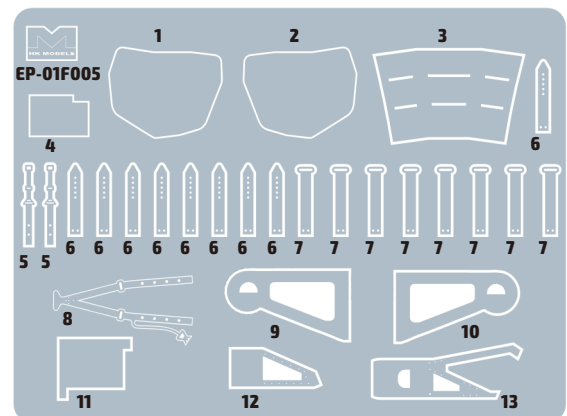



Decals

6 7  
 POS  
 6 7  
 POS

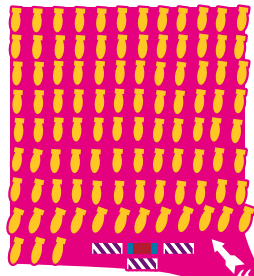

10  
 R5868  
 R5868

14  
 POMCMANUS

POTOTTENHAM

15

11  
 NO ENEMY PLANE WILL FLY  
 OVER THE REICH TERRITORY  
 HERMAN GOERING



5  
 S S

3  
 W4113  
 W4113

1 2  
 ZNY

1 2  
 ZNY

**HK Models 01F005**  
**Avro Lancaster B Mk.I** 1/48  
 PRINTED BY CARTOGRAF.COM MADE IN ITALY

Avro Lancaster 1/48

HK Models

PRINTED BY CARTOGRAF.COM  
 MADE IN ITALY

S16  
 S39  
 S38  
 S2  
 S2  
 S23  
 S24  
 S23  
 S31  
 S22  
 S8  
 S12  
 S12  
 S11  
 S20  
 S18  
 S14  
 S40  
 S41  
 S42  
 IP

MARKING

A

B Mk.I, W4118/ZN-Y, No. 106 Sqn. RAF, Syerston, UK,  
December 1942

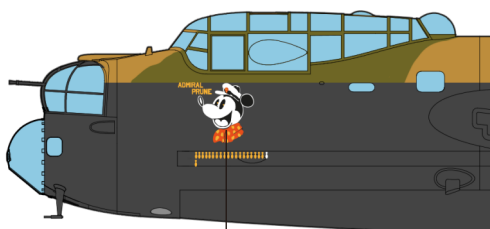
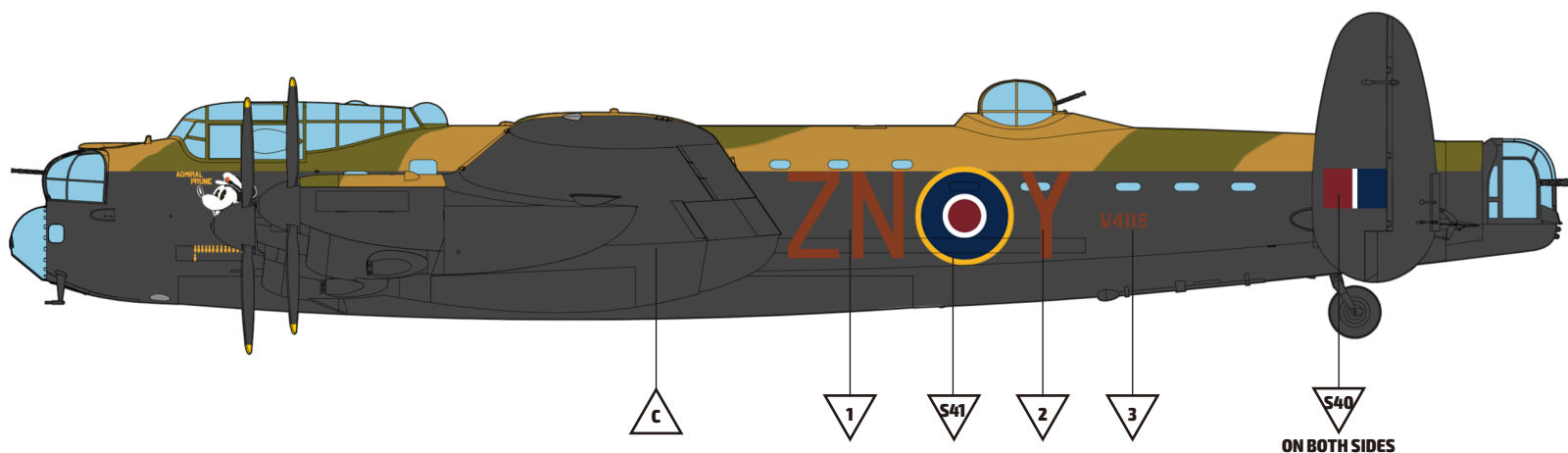

4

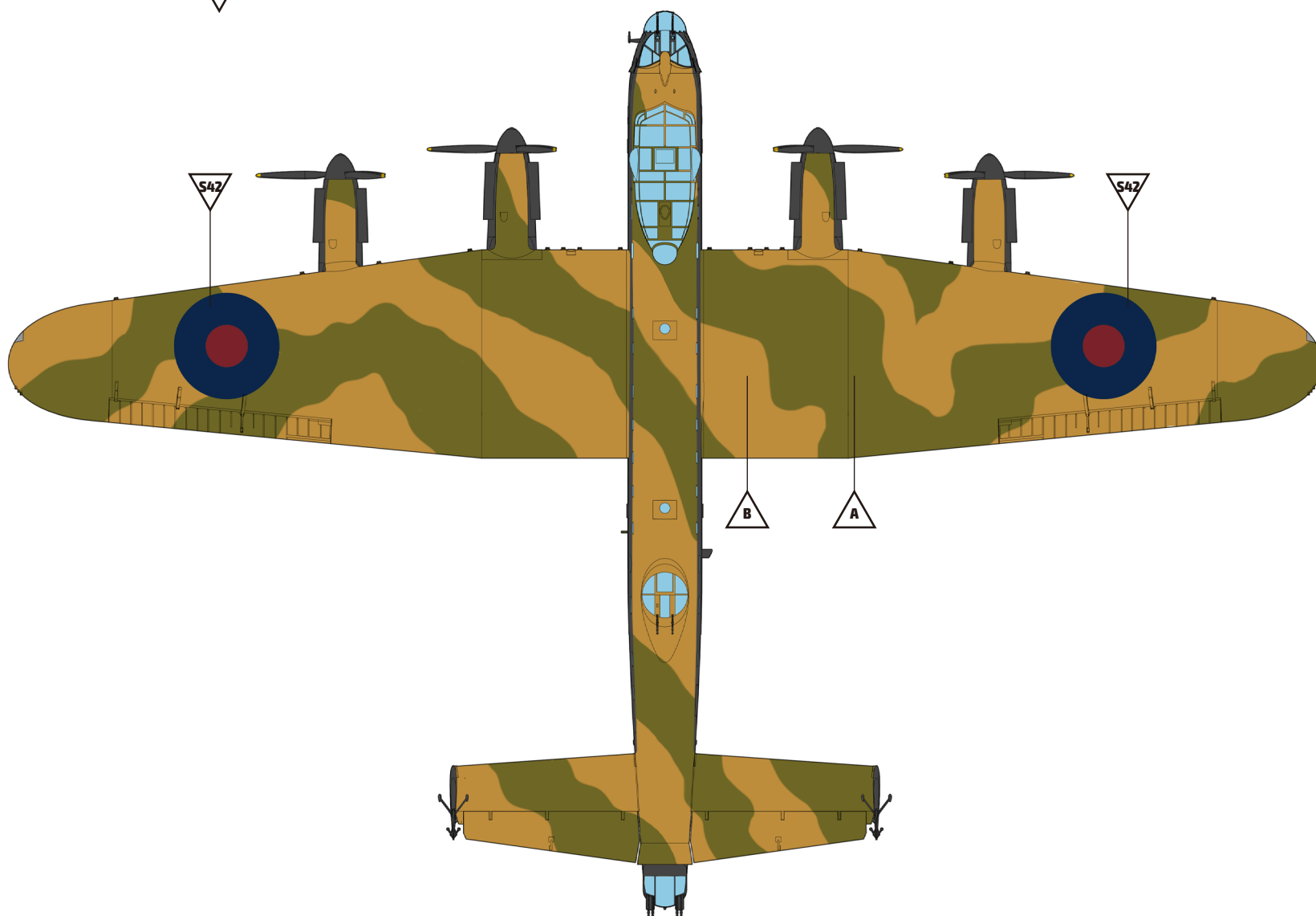

**MARKING**

**A**

**B Mk.I, W4118/ZN-Y, No. 106 Sqn. RAF, Syerston, UK, December 1942**

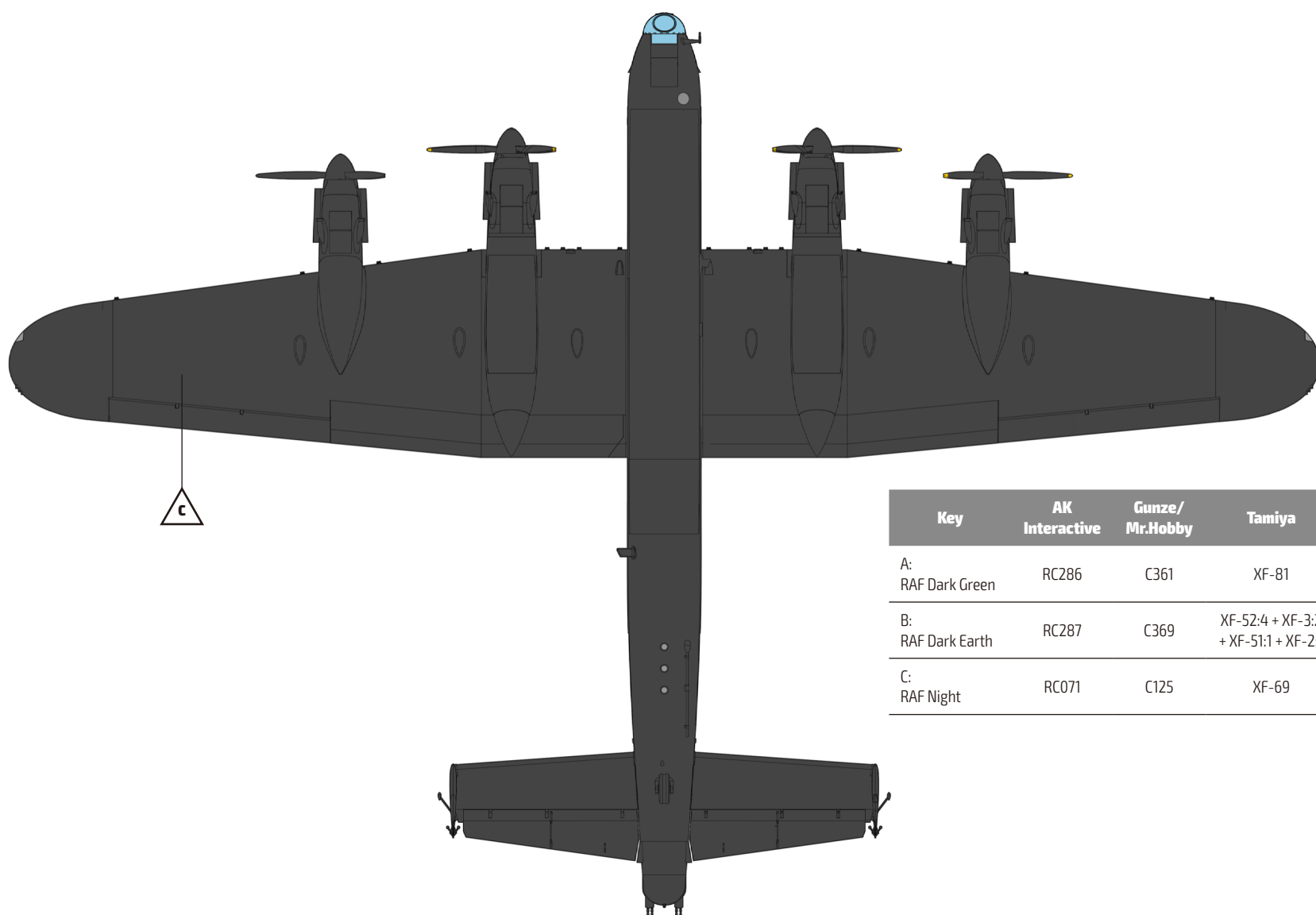
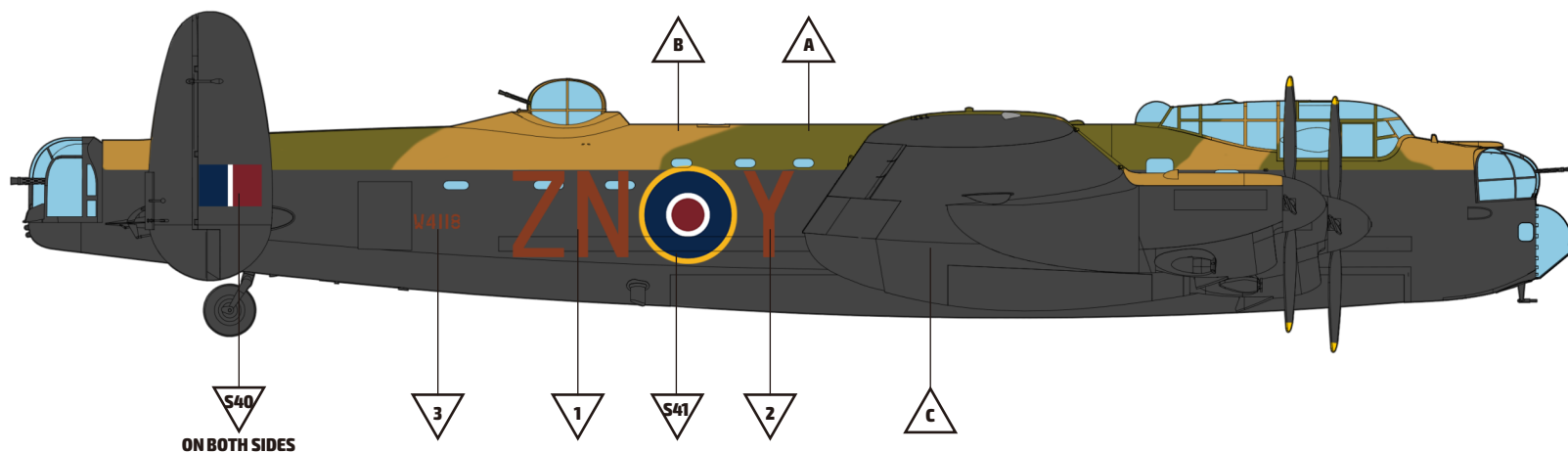

Key	AK Interactive	Gunze/Mr.Hobby	Tamiya
A: RAF Dark Green	RC286	C361	XF-81
B: RAF Dark Earth	RC287	C369	XF-52:4 + XF-3:2 + XF-51:1 + XF-2:1
C: RAF Night	RC071	C125	XF-69

MARKING

B

B Mk.I, R5868/PO-S, No.467 Sqn. (RAAF), Waddington, UK, May 1944

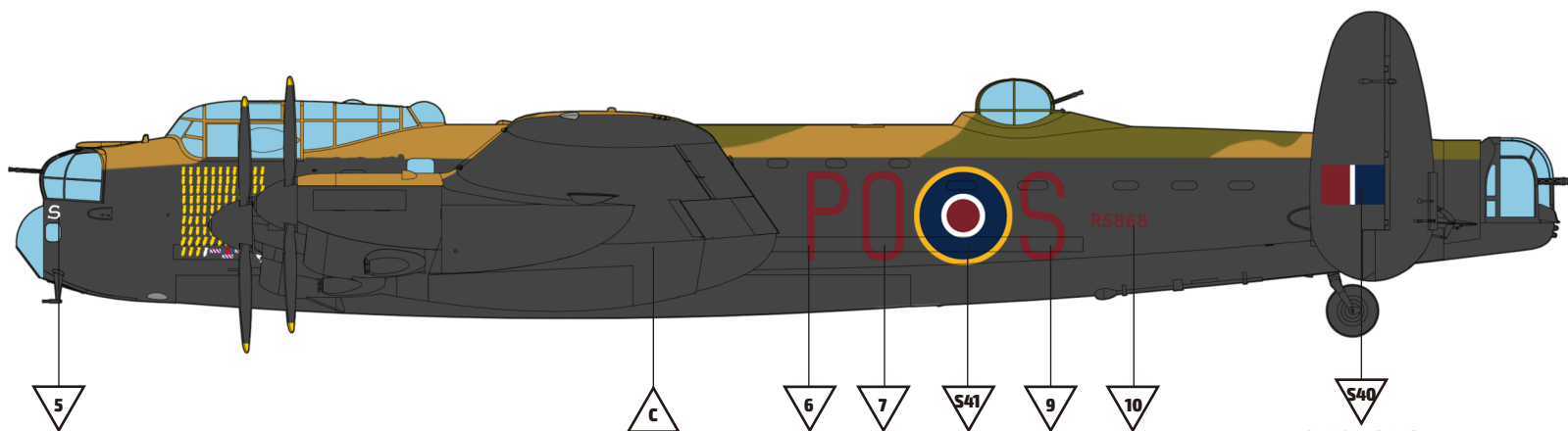

ON BOTH SIDES

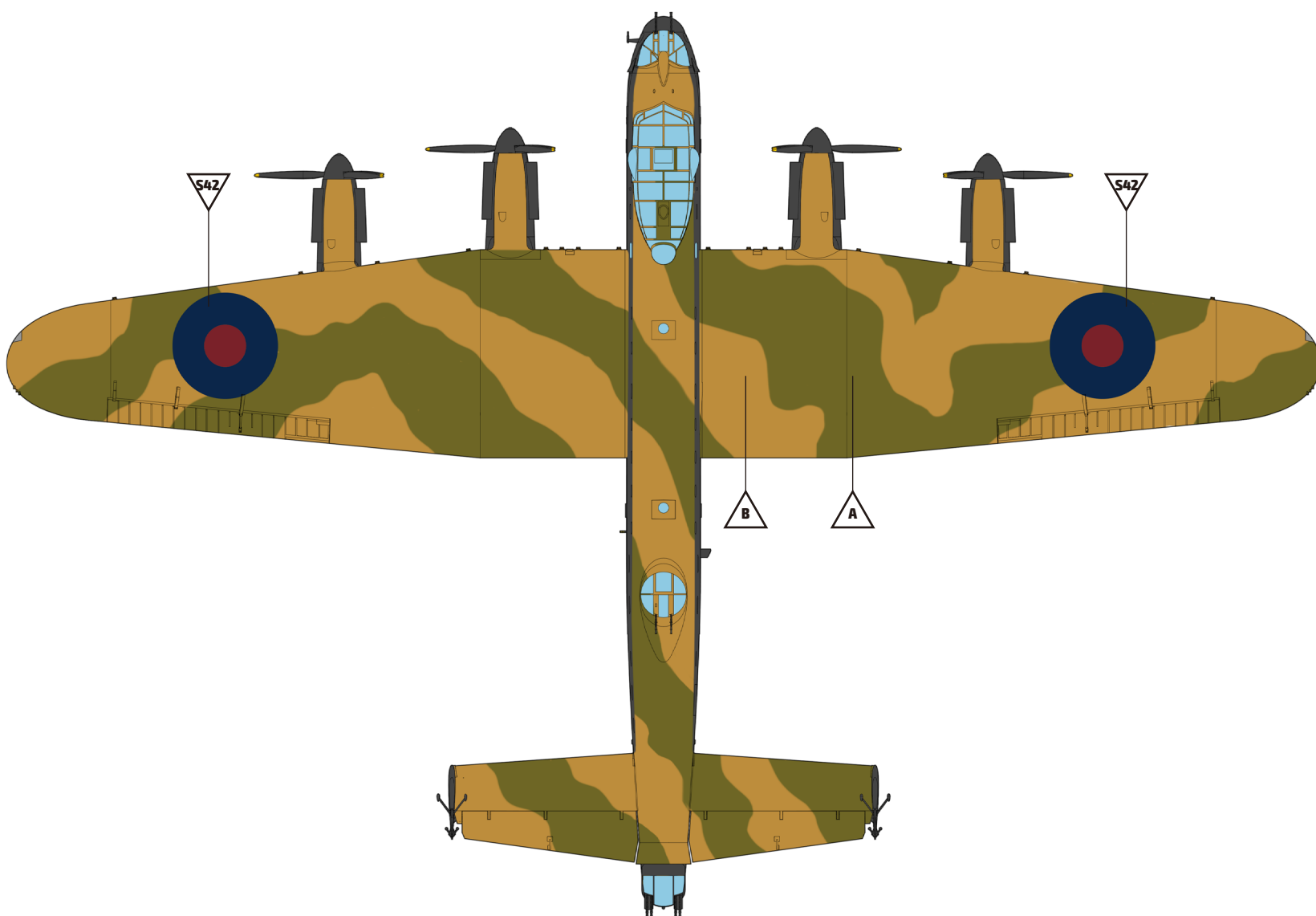
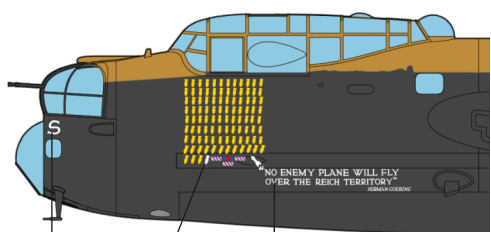

**MARKING**

**B**

**B Mk.I, R5868/PO-S, No.467 Sqn. (RAAF), Waddington, UK, May 1944**

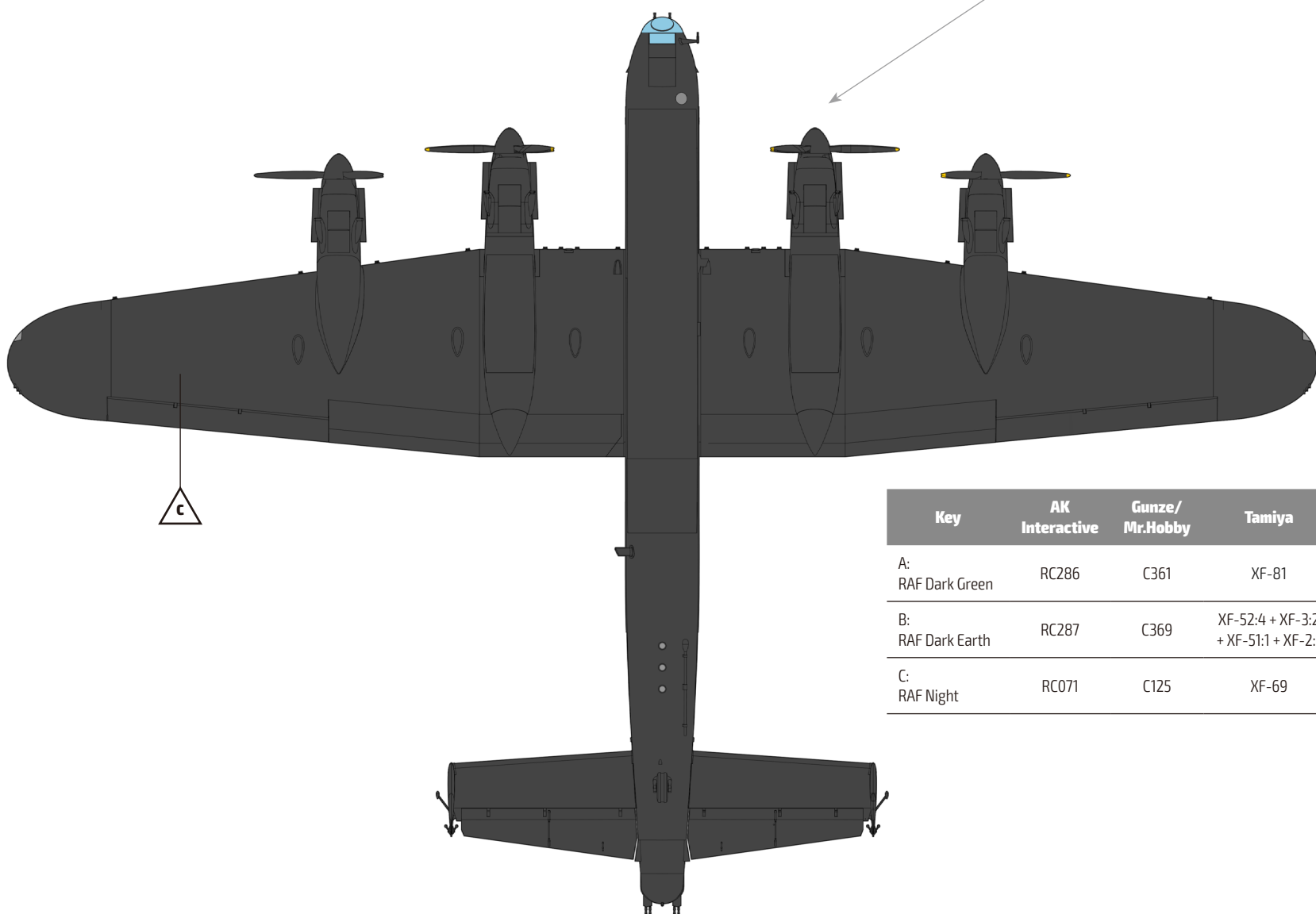
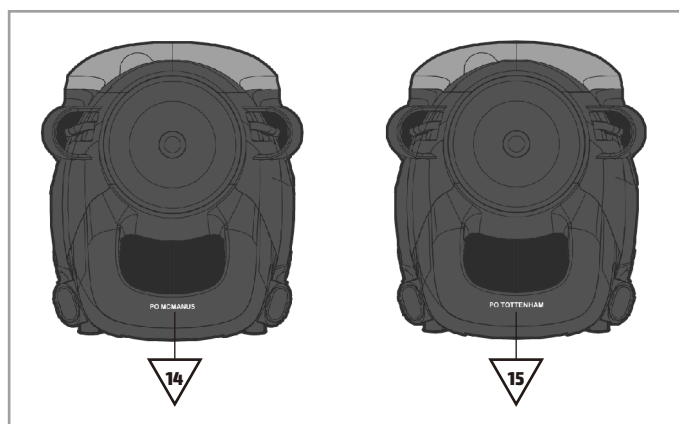
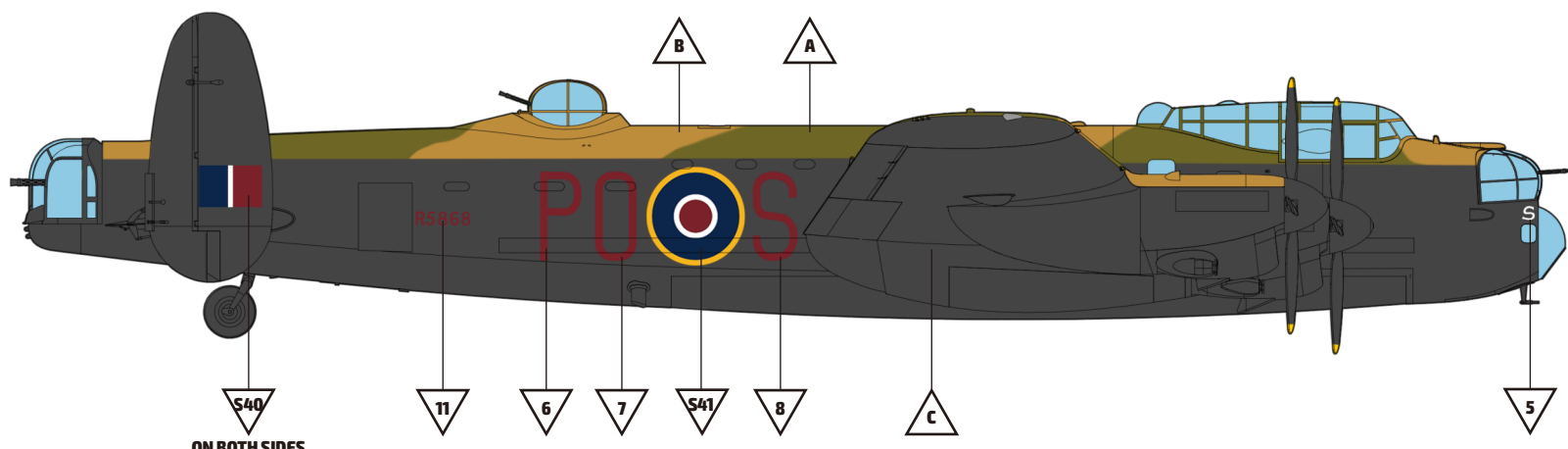

Key	AK Interactive	Gunze/Mr.Hobby	Tamiya
A: RAF Dark Green	RC286	C361	XF-81
B: RAF Dark Earth	RC287	C369	XF-52:4 + XF-3:2 + XF-51:1 + XF-2:1
C: RAF Night	RC071	C125	XF-69

# Common Stencils Placement Guide

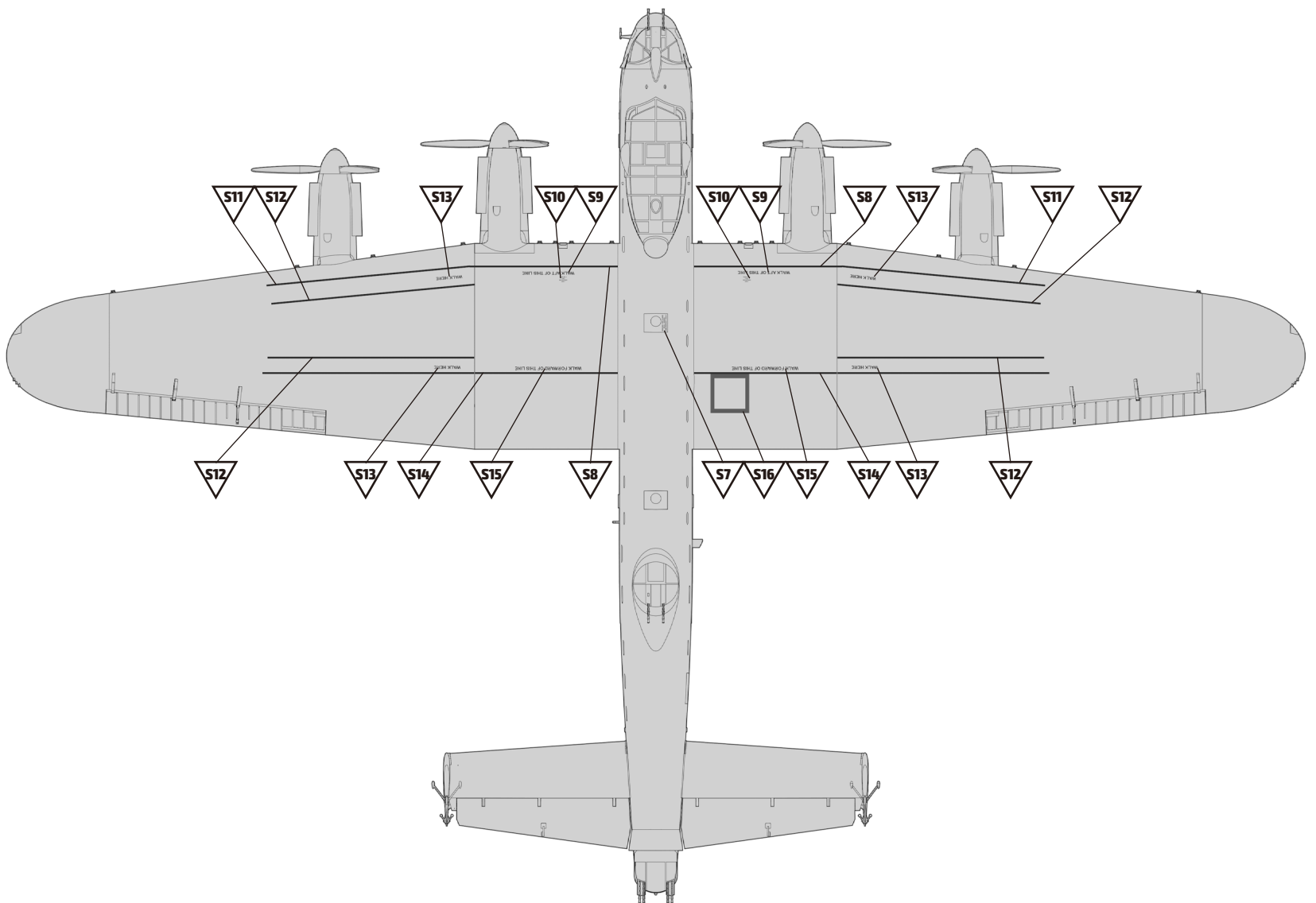
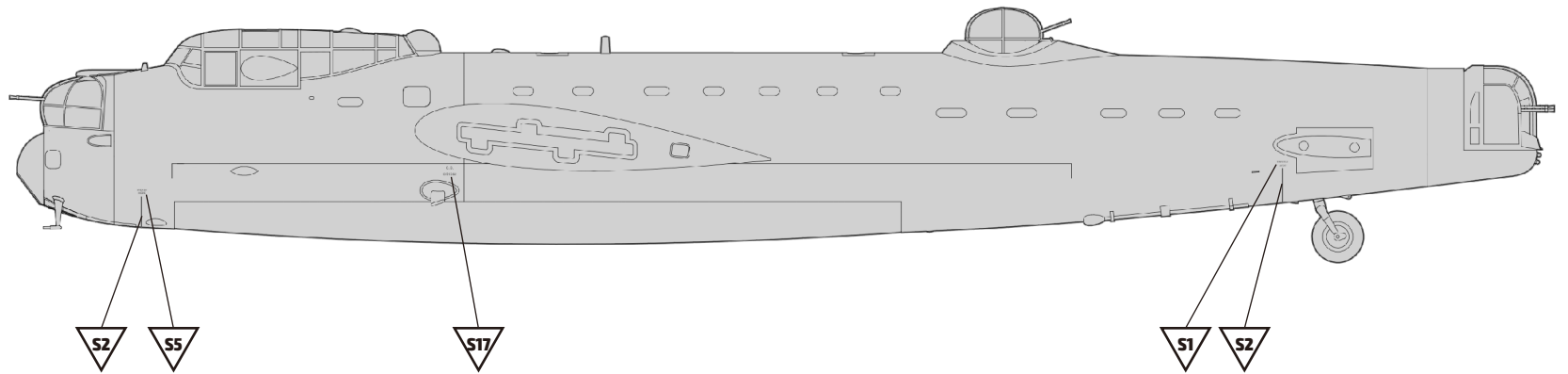

# Common Stencils Placement Guide

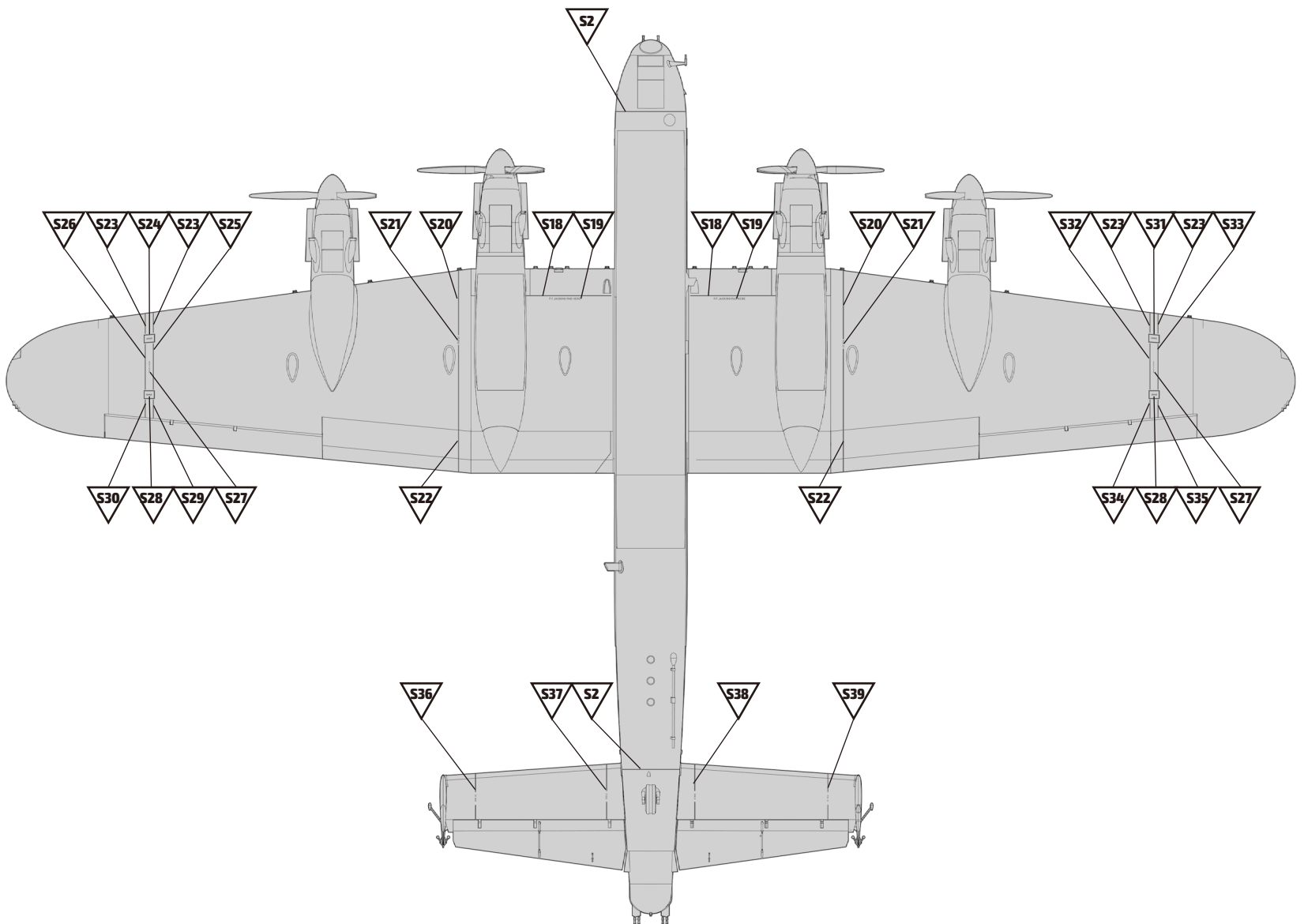
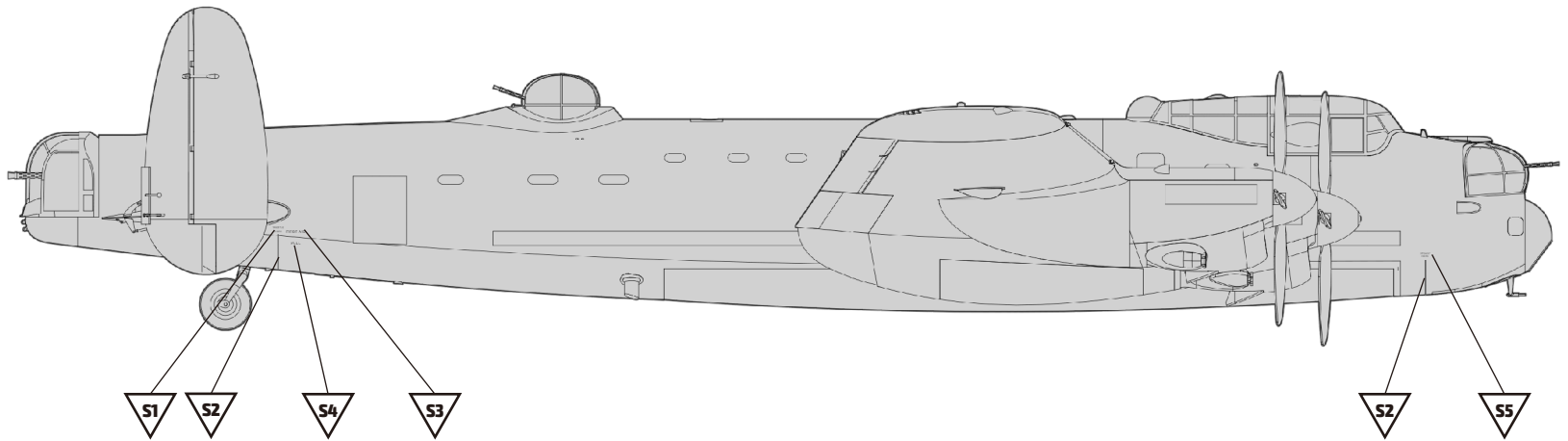

## Colour Guide

Key	AK Interactive	Tamiya	Gunze/Mr.Hobby
A: RAF Dark Green	RC286	XF-81	C361
B: RAF Dark Earth	RC287	XF-52:4 + XF-3:2 + XF-51:1 + XF-2:1	C369
C: RAF Night	RC036	XF-69	C125
D: RAF Interior Green	RC293	XF-71	C364
E: Dark Green Leather	AK2063	X-5	H6
F: Tan	RC019	XF-78	H27
G: Flat Yellow	RC008	XF-3	H413
H: Flat Red	RC006	XF-7	H13
I: Aluminium	AK479	XF-16	MC218
J: Gunmetal	RC015	X-10	MC214
K: Olive Drab	RC259	XF-62	H52
L: Steel	AK476	XF-56	MC213
M: Brass	AK475	X-12	MC219
N: Flat White	RC004	XF-2	H11
O: Rubber Black	RC022	XF-85	H77

In cooperation with:



[www.ak-interactive.com](http://www.ak-interactive.com)



Large  
Scale  
Modeller

[www.largescalemodeller.com](http://www.largescalemodeller.com)

General kit help/reference: **Large Scale Modeller**

Illustration, manual layout and format: **HK Models, Tomek Wajnka & AK-Interactive**

Manual and assistance: **AK-Interactive**

Introductory text: **Cees Broere**